

ACM6000T, ACM8000T, ACM2506, ACM2509, ACM2520

ACM8400T, ACM4509, ACM4520

ACM4000T

Automatic Calibration Module

Operating Manual



November, 2019

CONTENTS

| | |
|---|-----------|
| INTRODUCTION | 5 |
| 1 SAFETY INSTRUCTIONS | 6 |
| 2 GENERAL OVERVIEW | 7 |
| 2.1 Description | 7 |
| 2.2 Modification | 7 |
| 2.3 Specifications..... | 12 |
| 2.3.1 Technical Specifications | 12 |
| 2.3.2 Measurement Capabilities | 20 |
| 2.4 Principle of Operation | 24 |
| 2.4.1 Types of Calibration Standards | 29 |
| 2.4.2 Attenuator | 29 |
| 3 PREPARATION FOR USE | 30 |
| 3.1 Operating Restrictions..... | 30 |
| 3.2 Unpacking and Repacking | 30 |
| 3.2.1 Unpacking..... | 30 |
| 3.2.2 Packing | 31 |
| 3.3 Installation..... | 33 |
| 3.4 Software | 33 |
| 4 OPERATION PROCEDURE | 35 |
| 4.1 Front Panel | 35 |
| 4.1.1 Test Ports | 39 |
| 4.1.2 LED Status Indicator | 40 |
| 4.2 Side Panel | 41 |
| 4.2.1 Mini USB Connector | 41 |
| 4.2.2 USB B Connector | 41 |
| 4.3 Connection Diagrams | 41 |
| 4.3.1 Full One-Port Calibration..... | 41 |
| 4.3.2 One-Path Two-Port and Full Two-Port Calibration | 42 |
| 4.3.1 Full Three-Port Calibration | 43 |
| 4.3.2 Full Four-Port Calibration | 44 |
| 4.4 Module Work Session | 44 |
| 4.4.1 Module Preparation for Calibration..... | 44 |
| 4.5 Parameters Setting..... | 45 |
| 5 CALIBRATION | 46 |

| | |
|--|-----------|
| 5.1 Measurement Errors | 46 |
| 5.2 Calibration Types..... | 47 |
| 5.2.1 Full One-Port Calibration..... | 47 |
| 5.2.2 One-Path Two-Port Calibration..... | 47 |
| 5.2.3 Full Two-Port Calibration | 47 |
| 5.2.1 Full Three-Port Calibration..... | 48 |
| 5.2.2 Full Four-Port Calibration..... | 48 |
| 5.2.3 Unknown Thru..... | 48 |
| 5.3 Module Advantages | 49 |
| 5.4 Thermal Compensation | 49 |
| 5.5 Calibration Procedure | 50 |
| 5.6 User Characterization Procedure | 52 |
| 5.7 Confidence Check..... | 53 |
| 5.8 Automation | 55 |
| 6 Maintenance | 56 |
| 6.1 Introduction..... | 56 |
| 6.2 General Guidelines..... | 56 |
| 6.3 Maintenance Procedure..... | 56 |
| 6.3.1 Maintenance Activities..... | 56 |
| 6.3.2 Cleaning Connectors | 57 |
| 6.3.3 Gaging Connectors | 58 |
| 6.3.4 Connecting and Disconnecting Devices | 59 |
| 6.3.5 Ambient Conditions Control..... | 60 |
| 6.4 Factory Calibration | 61 |
| 7 Routine Repairs | 62 |
| 8 Storage Instructions..... | 62 |
| 9 Transportation | 63 |
| APPENDIX A (REFERENCE) MODULES OVERVIEW | 64 |

INTRODUCTION

This Operating Manual contains design, functional overview, detailed operation procedures, transportation and storage of automatic calibration modules (hereinafter referred to as Modules).

Before using the Module, please thoroughly read the following documents:

- This Operating Manual;
- The Operating Manual on vector network analyzer, which will be used with the Module;
- The Programming manual.

Maintenance and operation of the Module should be performed by qualified engineers with basic experience in operating of microwave circuits and PC.

The manufacturer reserves the right to introduce any changes in Module design and documentation which do not affect its rated metrological characteristics without customers' notification.

WARNING: THIS DOCUMENT IS FOR INFORMATIONAL PURPOSES ONLY AND MAY NOT BE REDISTRIBUTED, COPIED OR REPRODUCED WITHOUT PRIOR WRITTEN CONSENT OF COPPER MOUNTAIN TECHNOLOGIES.

COMMERCIAL USAGE OF THIS DOCUMENT, OR ANY PART OF IT, IS PROHIBITED WITHOUT THE WRITTEN CONSENT OF THE MANUFACTURER.

The manufacturer is not responsible for any consequences of the Module misuse or failure to comply with safety rules or other recommended safety precautions.

The following abbreviations are used in this Manual:

PC - Personal Computer

DUT - Device Under Test

IF - Intermediate Frequency

VNA - Vector Network Analyzer

1 SAFETY INSTRUCTIONS

Observe all general safety precautions related to the operation of electrically energized equipment.



The Module should be used only by skilled and thoroughly trained personnel with the required skills and knowledge of safety precautions.

Connect the post marked  on the body of the VNA to which the Module will be connected to the body of the controlling PC before you start operation.

Exceeding maximum input power of RF signal or maximum DC voltage specified on the front panel of the Module can result in the Module breakdown.

Never operate the Module if the USB cable is damaged.

Protection from electrostatic discharge



Make sure to protect the work place from electrostatic discharge.

Electrostatic discharge can damage the Module when connected or disconnected from the VNA, during the connectors cleaning, or visual inspection.

Static charge can build up on your body and damage the sensitive circuits of internal components of both the Module and the VNA being calibrated. To avoid damage from electric discharge, observe the following:

Always discharge the static charge accumulated on your body before you touch the Module or any other sensitive to static electricity devices.

Always use a desktop anti-static mat under the DUT.

Always wear a grounding wrist strap connected to the desktop anti-static mat via daisy-chained 1 MΩ resistor.

2 GENERAL OVERVIEW

2.1 Description

Automatic Calibration Module is designed for calibration (error correction) of vector network analyzers in automatic mode.

Calibration is performed by automatically connecting the reflection and transmission impedance states to the VNA test ports.

Calibration enables determination of systematic errors in accordance with the VNA model. The process of mathematical compensation (numerical reduction) for measurement systematic errors is called **error correction**.

Usage of the Module instead of a mechanical calibration kit has a number of advantages which ensure high measurement accuracy and longer service life of the VNA test ports. The measurement accuracy is achieved by the precision Module standards (states) description, by the stability of the selected configuration and by the application of temperature drift functions and self-diagnosis in the form of confidence check. Single module connection during calibration allows to:

- Extend the VNA ports service life;
- Reduce technical staff workload and risk of human error;
- Make the measurement process most efficient.

The Module control protocol is based on the USBTMC-USB488 standard.

2.2 Modification

The automatic calibration modules differ in operating frequency range and number of ports. Their functional features are briefly described in Table 2.1 and Appendix A. The Module appearance is shown in section 4.1.

Table 2.1 Functional Features

| Module | Frequency range |
|--------------------------|-------------------|
| 50 Ohm two-port Modules | |
| ACM6000T | 20 kHz to 6 GHz |
| ACM2506 | 20 kHz to 6.5 GHz |
| ACM8000T | 100 kHz to 8 GHz |
| ACM2509 | 20 kHz to 9 GHz |
| ACM2520 ¹⁾ | 100 kHz to 20 GHz |
| 50 Ohm four-port Modules | |
| ACM8400T | 100 kHz to 8 GHz |
| ACM4509 | 100 kHz to 9 GHz |
| ACM4520 ¹⁾ | 100 kHz to 20 GHz |
| 75 Ohm two-port Modules | |
| ACM4000T | 20 kHz to 4 GHz |

During calibration, the Modules are controlled by the VNA software installed at the personal computer. The USB 2.0 interface is used for control.

The Modules feature several hardware configurations depending on the connector types of PORT A, PORT B and, if available, PORT C and PORT D. Tables 2.2 - 2.10 indicate possible connector types for each Module.

The Module supply package is specified in Table 2.11.

¹⁾ The upper frequency point of ACM2520 and ACM4520 with type N connectors is 18 GHz.

Table 2.2 ACM6000T hardware configurations

| Model | Connector type | |
|--------------|----------------|----------------|
| | Port A | Port B |
| ACM6000T-011 | type N, female | type N, female |
| ACM6000T-012 | type N, male | type N, female |
| ACM6000T-111 | 3.5 mm, female | 3.5 mm, female |
| ACM6000T-112 | 3.5 mm, male | 3.5 mm, female |

Table 2.3 ACM8000T hardware configurations

| Model | Connector type | |
|--------------|----------------|----------------|
| | Port A | Port B |
| ACM8000T-011 | type N, female | type N, female |
| ACM8000T-012 | type N, male | type N, female |
| ACM8000T-111 | 3.5 mm, female | 3.5 mm, female |
| ACM8000T-112 | 3.5 mm, male | 3.5 mm, female |

Table 2.4 ACM2506 hardware configurations

| Model | Connector type | |
|-------------|----------------|----------------|
| | Port A | Port B |
| ACM2506-011 | type N, female | type N, female |
| ACM2506-012 | type N, male | type N, female |
| ACM2506-111 | 3.5 mm, female | 3.5 mm, female |
| ACM2506-112 | 3.5 mm, male | 3.5 mm, female |

Table 2.5 ACM2509 hardware configurations

| Model | Connector type | |
|-------------|----------------|----------------|
| | Port A | Port B |
| ACM2509-011 | type N, female | type N, female |
| ACM2509-012 | type N, male | type N, female |
| ACM2509-111 | 3.5 mm, female | 3.5 mm, female |
| ACM2509-112 | 3.5 mm, male | 3.5 mm, female |

Table 2.6 ACM2520 hardware configurations

| Model | Connector type | |
|-------------|----------------|----------------|
| | Port A | Port B |
| ACM2520-011 | type N, female | type N, female |
| ACM2520-012 | type N, male | type N, female |
| ACM2520-111 | 3.5 mm, female | 3.5 mm, female |
| ACM2520-112 | 3.5 mm, male | 3.5 mm, female |

Table 2.7 ACM8400T hardware configurations

| Model | Connector type | |
|----------------|----------------|----------------|
| | Port A/C | Port B/D |
| ACM8400T-01111 | type N, female | type N, female |
| ACM8400T-01212 | type N, male | type N, female |
| ACM8400T-11111 | 3.5 mm, female | 3.5 mm, female |
| ACM8400T-11212 | 3.5 mm, male | 3.5 mm, female |

Table 2.8 ACM4509 hardware configurations

| Model | Connector type | |
|---------------|----------------|----------------|
| | Port A/C | Port B/D |
| ACM4509-01111 | type N, female | type N, female |
| ACM4509-01212 | type N, male | type N, female |
| ACM4509-11111 | 3.5 mm, female | 3.5 mm, female |
| ACM4509-11212 | 3.5 mm, male | 3.5 mm, female |

Table 2.9 ACM4520 hardware configurations

| Model | Connector type | |
|---------------|----------------|----------------|
| | Port A/C | Port B/D |
| ACM4520-01111 | type N, female | type N, female |
| ACM4520-01212 | type N, male | type N, female |
| ACM4520-11111 | 3.5 mm, female | 3.5 mm, female |
| ACM4520-11212 | 3.5 mm, male | 3.5 mm, female |

Table 2.10 ACM4000T hardware configurations

| Model | Connector type | |
|--------------|-------------------|-------------------|
| | Port A | Port B |
| ACM4000T-511 | type N 75, female | type N 75, female |
| ACM4000T-512 | type N 75, male | type N 75, female |

Table 2.11 Supply kit

| Name | Quantity, pcs |
|------------------------------|------------------|
| Automatic calibration module | 1 |
| USB cable | 1 |
| Operating manual | 1 |

Notes:

1 A specific model of automatic calibration module is selected in the order.

2 The operating manual is provided in electronic format on the USB flash drive.

2.3 Specifications

2.3.1 Technical Specifications

The technical specifications of different models are shown in Table 2.12.

The Module ensures effective VNA parameters within the temperature range of 18 °C to 28 °C and in case of temperature change of no more than by ± 1 °C after full one- or multiple-port calibration at the output power level of -5 dBm.

Precision test cables and adapters should be used to ensure the effective parameters shown in Table 2.13. The usage of general-purpose accessories can increase the VNA error margin.

Table 2.12 Basic technical specifications

| Parameter | Value |
|--|--------------------------|
| Frequency range, MHz: | |
| ACM4000T | 0.02 to 4000 |
| ACM6000T | 0.02 to 6000 |
| ACM2506 | 0.02 to 6500 |
| ACM8000T, ACM8400T | 0.10 to 8000 |
| ACM2509 | 0.02 to 9000 |
| ACM4509 | 0.10 to 9000 |
| ACM2520, ACM4520 ²⁾ | 0.10 to 20,000 |
| Number of ports: | |
| ACM4000T, ACM6000T, ACM8000T, ACM2506, ACM2509, ACM2520 | 2 |
| ACM8400T, ACM4509, ACM4520 | 4 |
| Port parameters: | |
| Connector type | As per Tables 2.2 - 2.10 |
| Impedance, Ohm: | |
| ACM6000T, ACM8000T, ACM8400T, ACM2506, ACM2509, ACM4509, ACM2520, ACM4520 | 50 |
| ACM4000T | 75 |
| Max number of characterization points | 1601 |

²⁾ The upper frequency point of ACM2520 and ACM4520 with type N connectors is 18 GHz.

2 GENERAL OVERVIEW

| Parameter | Value |
|--|--|
| Max ³⁾ power, dBm ⁴⁾ | |
| ACM4000T, ACM6000T, ACM2506, ACM2509, ACM2520, ACM4520 | 0 |
| ACM8000T, ACM8400T, ACM4509 | -5 |
| Max DC voltage, V | ±10 |
| Damage level, dBm ⁵⁾ | +18 |
| Damage DC voltage, V | |
| ACM4000T, ACM6000T, ACM8000T, ACM2506, ACM2509, ACM8400T, ACM4509 | ±35 |
| ACM2520 | ±5 |
| ACM4520 | ±10 |
| Connection to controlling computer: | |
| Connector type | |
| ACM4000T, ACM6000T, ACM8000T, ACM8400T, ACM2506, ACM2509, ACM4509 | mini USB |
| ACM2520, ACM4520 | USB B |
| Interface | USB 2.0 |
| Support standard | Proprietary ⁶⁾ USBTMC-USB488 ⁷⁾ |
| Power consumption, W, no more than: | |
| ACM4000T, ACM6000T, ACM8000T, ACM2506, ACM2509 | 0.20 |
| ACM8400T, ACM4509, ACM4520 | 0.60 |
| ACM2520 | 0.25 |

³⁾ Exceeding maximum values will increase the VNA measurement error.

⁴⁾ dBm refers to dB in relation to 1 mW.

⁵⁾ Exceeding the threshold values will result in the Module breakdown.

⁶⁾ Proprietary protocol is a closed protocol designed by Copper Mountain Technologies for controlling own-produced modules.

⁷⁾ Please, contact Technical Support Team for the availability of USBTMC-USB488 control protocol on a specific module.

| Parameter | Value |
|--|---------------------|
| Operating mode setting time, min, no more than | 15 |
| Setting time ⁸⁾ , ms | |
| ACM4000T, ACM6000T, ACM2506, ACM2509 ⁹⁾ , ACM2520, ACM4520 | 500 |
| ACM8000T, ACM8400, ACM4509 | 2000 |
| Dimensions (length×width×height), mm, no more than: | |
| ACM4000T, ACM6000T, ACM8000T, ACM2506, ACM2509 | 115 × 40 × 25 |
| ACM8400T, ACM4509 | 115 × 74 × 25 |
| ACM2520 | 106.4 × 55.0 × 28.0 |
| ACM4520 | 110 × 89 × 27 |
| Weight, kg, no more than: | |
| ACM4000T, ACM6000T, ACM8000T, ACM2506, ACM2509 | 0.350 |
| ACM8400T, ACM4509 | 0.550 |
| ACM2520 | 0.435 |
| ACM4520 | 0.900 |
| Operating conditions: | |
| Ambient temperature, °C | +5 to +40 |
| Relative humidity at the temperature of +25 °C, %, no more than | 90 |
| Atmospheric pressure, kPa | 70.0 to 106.7 |

Table 2.13 Effective (corrected) VNA parameters ensured by the Module¹⁰⁾

⁸⁾ Delay between the change of the ACM switch state and the start of the measurement.

⁹⁾ Setting time of earlier hardware revision is 2000 ms.

¹⁰⁾ Effective parameters depend on accuracy of original standards used for factory module characterization (see section 2.3.2). The accuracy level is subject to agreement between the customer and Copper Mountain Technologies during the Module manufacture. In this case, the effective parameters can be different from those specified in the Table.

2 GENERAL OVERVIEW

| Frequency range | Ed | Es | El | $(Er-1)$ | $(Et-1)$ |
|---|-------|-------|-------|----------|----------|
| ACM4000T | | | | | |
| 20 kHz to 1 MHz | 0.016 | 0.025 | 0.016 | 0.017 | 0.017 |
| over 1 MHz to upper frequency | 0.008 | 0.011 | 0.008 | 0.012 | 0.012 |
| ACM6000T, ACM8000T, ACM8400T, ACM2506, ACM2509, ACM4509 | | | | | |
| From lower frequency to 1 MHz | 0.016 | 0.025 | 0.016 | 0.017 | 0.017 |
| over 1 MHz to upper frequency | 0.005 | 0.010 | 0.005 | 0.005 | 0.007 |
| ACM2520, ACM4520 | | | | | |
| 100 kHz to 1 MHz | 0.016 | 0.025 | 0.016 | 0.017 | 0.017 |
| over 1 MHz to 9 GHz | 0.005 | 0.010 | 0.005 | 0.005 | 0.007 |
| over 9 GHz to upper frequency | 0.010 | 0.016 | 0.010 | 0.005 | 0.007 |
| <p>where Ed is directivity; Es is source match; El is load match; $(Er-1)$ is reflection tracking; $(Et-1)$ is transmission tracking.</p> | | | | | |

Table 2.14 Effective (corrected) VNA parameters ensured by ACM4000T

Effective parameters in the frequency range:

20 kHz to 1 MHz

| | |
|--------------------------------|------------|
| Directivity, dB, no less than | 36 |
| Source match, dB, no less than | 32 |
| Load match, dB, no less than | 36 |
| Reflection tracking, dB | ± 0.15 |
| Transmission tracking, dB | ± 0.15 |

over 1 MHz to upper frequency point

| | |
|--------------------------------|------------|
| Directivity, dB, no less than | 42 |
| Source match, dB, no less than | 39 |
| Load match, dB, no less than | 42 |
| Reflection tracking, dB | ± 0.10 |
| Transmission tracking, dB | ± 0.10 |

2 GENERAL OVERVIEW

Table 2.15 Effective (corrected) VNA parameters ensured by ACM6000T, ACM8000T, ACM8400T, ACM2506, ACM2509, ACM4509

Effective parameters in the frequency range:

from lower frequency point to 1 MHz

| | |
|--------------------------------|------------|
| Directivity, dB, no less than | 36 |
| Source match, dB, no less than | 32 |
| Load match, dB, no less than | 36 |
| Reflection tracking, dB | ± 0.15 |
| Transmission tracking, dB | ± 0.15 |

over 1 MHz to upper frequency point

| | |
|--------------------------------|------------|
| Directivity, dB, no less than | 46 |
| Source match, dB, no less than | 40 |
| Load match, dB, no less than | 46 |
| Reflection tracking, dB | ± 0.04 |
| Transmission tracking, dB | ± 0.06 |

Table 2.16 Effective (corrected) VNA parameters ensured by ACM2520, ACM4520

Effective parameters in the frequency range:

100 kHz to 1 MHz

| | |
|--------------------------------|------------|
| Directivity, dB, no less than | 36 |
| Source match, dB, no less than | 32 |
| Load match, dB, no less than | 36 |
| Reflection tracking, dB | ± 0.15 |
| Transmission tracking, dB | ± 0.15 |

over 1 MHz to 9 GHz

| | |
|--------------------------------|------------|
| Directivity, dB, no less than | 46 |
| Source match, dB, no less than | 40 |
| Load match, dB, no less than | 46 |
| Reflection tracking, dB | ± 0.04 |
| Transmission tracking, dB | ± 0.06 |

over 9 GHz to upper frequency point

| | |
|--------------------------------|------------|
| Directivity, dB, no less than | 40 |
| Source match, dB, no less than | 36 |
| Load match, dB, no less than | 40 |
| Reflection tracking, dB | ± 0.04 |
| Transmission tracking, dB | ± 0.06 |

2.3.2 Measurement Capabilities

The VNA software controlling the Module features a wide range of functions. You can see their brief description below. See the VNA operating manual for more detailed information.

Functional capabilities are divided into the following groups:

| |
|-----------------------|
| Automatic calibration |
| Characterization |
| Automatic orientation |
| Thermal compensation |
| Confidence check |
| Automation |

Automatic calibration

| | |
|-------------|---|
| Calibration | Calibration of a test setup (which includes the VNA, cables, and adapters) significantly increases the accuracy of measurements. Calibration allows for correction of errors caused by imperfections in the measurement system: system directivity, source and load match, tracking, and isolation. |
|-------------|---|

| | |
|------------------------------|--|
| Automatic calibration of VNA | The Module enables calibration in “one click”. The calibration is performed fully automatically, including switching between different module states, their measurement and calibration coefficients calculation by the software using the data stored in the Module memory. |
|------------------------------|--|

| | |
|---------------------|---|
| Calibration methods | <p>All Modules support the following calibration methods:</p> <ul style="list-style-type: none"> Full one-port calibration; One-path two-port calibration; Full two-port calibration. <p>Four-port Modules support the following additional calibration methods:</p> <ul style="list-style-type: none"> Full three-port calibration; Full four-port calibration. |
|---------------------|---|

| | |
|---------------------------|---|
| Full one-port calibration | Method of calibration performed for one-port reflection measurements. It ensures high accuracy. |
|---------------------------|---|

| | |
|-------------------------------|---|
| One-path two-port calibration | Method of calibration performed for reflection and one-way transmission measurements, for example for measuring S_{11} and S_{21} only. It ensures high accuracy for reflection measurements, and reasonable accuracy for transmission measurements. |
| Full two-port calibration | Method of calibration performed for full S-parameter matrix measurement of a two-port DUT. Method also known as SOLT: Short, Open, Load, Thru. It ensures high accuracy. |
| Full three-port calibration | Method of calibration performed for full S-parameter matrix measurement of a three-port DUT. It ensures high accuracy. |
| Full four-port calibration | Method of calibration performed for full S-parameter matrix measurement of a four-port DUT. It ensures high accuracy. |
| Unknown Thru | <p>The usage of a reciprocal two-port device with loss values of no more than 10 dB for full two-, three- and four-port calibration enables correction of VNA parameters for measuring parameters of non-insertion devices. Non-insertion devices are the devices having same-gender connectors of any type, and different-gender or same-gender connectors of different types.</p> <p>The Module memory stores S-parameters of the thru which are used for calibration coefficients calculation. The said parameters are not applied for the Unknown Thru algorithm.</p> |
| Characterization | |
| Characterization | <p>Characterization is a table of S-parameters of all the states of the Module switches, stored in its memory.</p> <p>The Module has two memory sections. The first one is write-protected and contains factory characterization. The second memory section allows the user storing up to three user characterizations. Before calibration, the user can select factory characterization or one of user characterizations.</p> |
| Factory characterization | Factory characterization is performed during the Module manufacture. The factory characterization data is stored in the write-protected section of the Module memory. |
| User characterization | The user characterization option is provided for saving new S-parameters of the Module after connecting adapters to its ports. The user can create up to three different characterizations. The user characterization can be performed using the VNA software. The characterization data is stored in the Module memory section, which can be overwritten. |

Automatic orientation

| | |
|-----------------------|--|
| Orientation | Orientation means relating the Module ports to the test ports of the VNA. While the VNA ports are indicated by numbers, the Module ports are indicated by letters A, B, C and D. |
| Orientation method | The user can select manual or automatic orientation method. |
| Automatic orientation | For automatic orientation, the VNA software determines the Module orientation each time prior to its calibration or characterization. |

Thermal compensation

| | |
|---|---|
| Thermal compensation | Thermal compensation is a software function of S-parameters correction based on known temperature dependence data and the temperature sensor data inside the Module. Temperature dependence of each Module with factory characterization is determined during its manufacture and stored in its memory. The user can enable or disable thermal compensation function. |
| Thermal compensation of user characterization | Thermal compensation of user characterization is based on coefficients obtained during the Module manufacture. In case operating frequency range and/or the number of frequency points of user and factory characterization are not the same, linear interpolation of thermal compensation coefficients is used for user characterization data. |

Confidence check

| | |
|------------------|---|
| Confidence check | <p>Confidence check is the test of current calibration performed either by the Module, or by any other method.</p> <p>Confidence check features simultaneous indication of attenuator S-parameters measured and stored in the Module memory.</p> <p>Math (division) function for data and memory is used for a detailed comparison.</p> |
|------------------|---|

Automation

| | |
|-----------------|--|
| Operating modes | <p>The Module is controlled using the USB interface. CMT's VNA software or VISA library have to be installed at the controlling PC. The VISA comprehensive library allows controlling measurement equipment in almost all programming languages, i.e. C/C++, Visual Basic, MATLAB, LabVIEW, etc. The Module features the USBTMC-USB488 standard control protocol. The Programming Manual includes descriptions of commands used for controlling.</p> |
|-----------------|--|

2.4 Principle of Operation

The Module contains several different transmission and reflection impedance states and electronic changeover switches, two or four RF connectors and a USB connector. RF connectors are intended for connecting to VNA test ports, and a USB connector is intended for controlling.

| Module | States |
|---|--|
| ACM4000T, ACM6000T, ACM2506 and ACM2509 | 6 reflection states (three for each port), a thru and an attenuator |
| ACM8000T | 10 reflection states (five for each port), a thru and an attenuator |
| ACM2520 | 8 reflection states (four for each port), a thru and an attenuator |
| ACM8400T and ACM4509 | 16 reflection states (four for each port), a thru and an attenuator |
| ACM4520 | 12 reflection states (three for each port), a thru and an attenuator |

Calibration is performed by automatically connecting internal transmission and reflection impedance states to the VNA test ports.

Calibration allows determining systematic errors according to the VNA model. The data obtained after calibration is used to correct S-parameter measurement results in order to increase measurement accuracy.

Block diagrams of Modules are represented in figures 2.1 – 2.6.

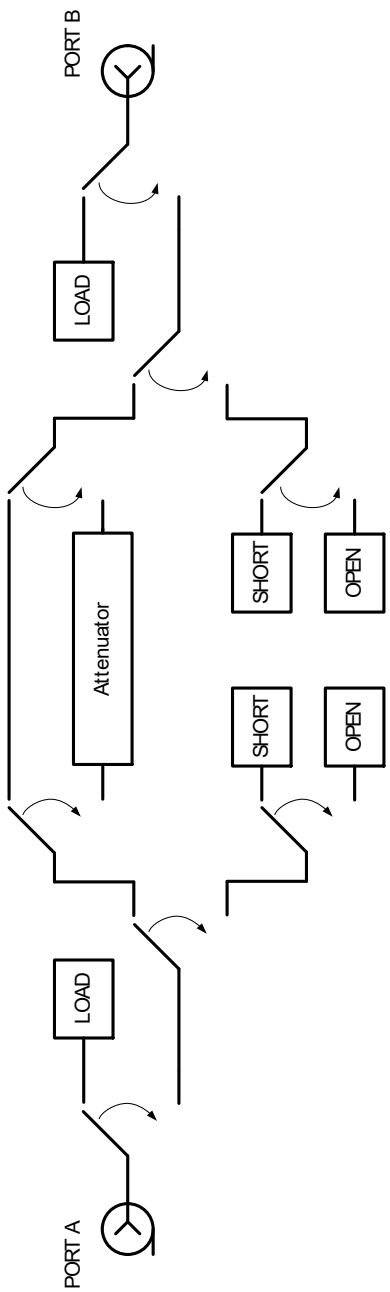

Figure 2.1 Block diagram of ACM4000T and ACM6000T

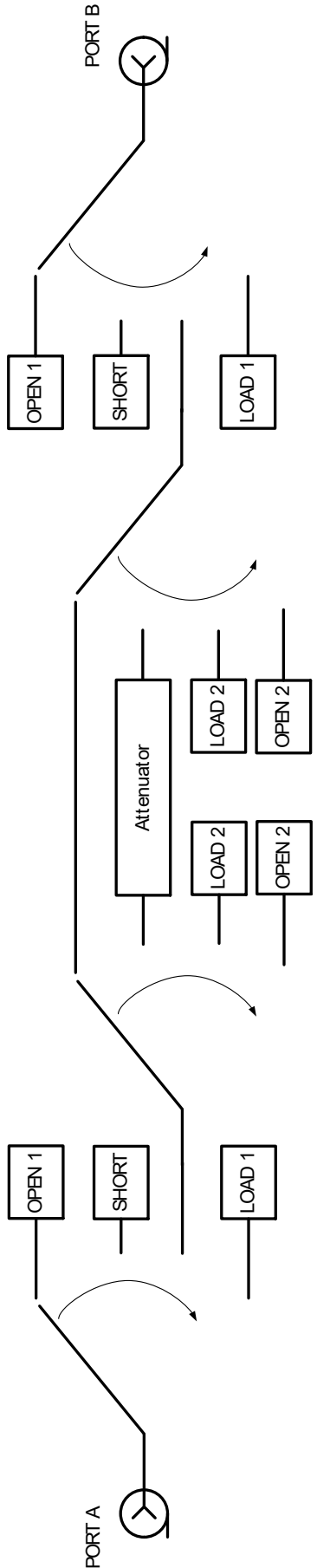

Figure 2.2 Block diagram of ACM8000T

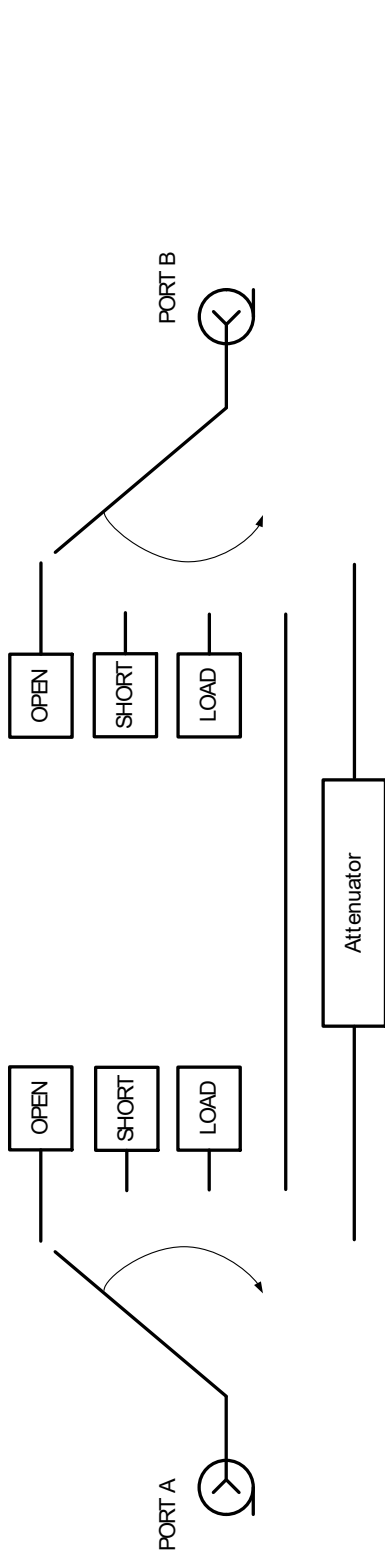

Figure 2.3 Block diagram of ACM2506 and ACM2509

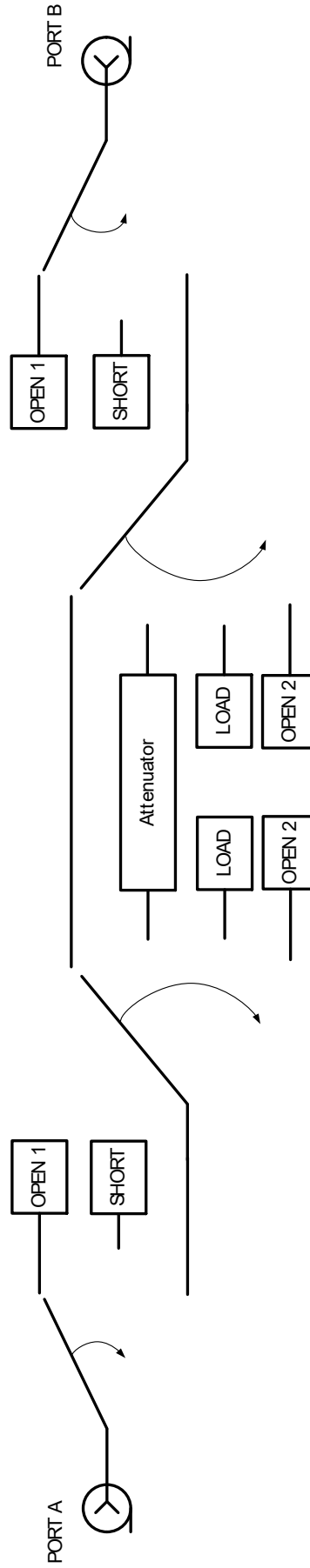

Figure 2.4 Block diagram of ACM2520

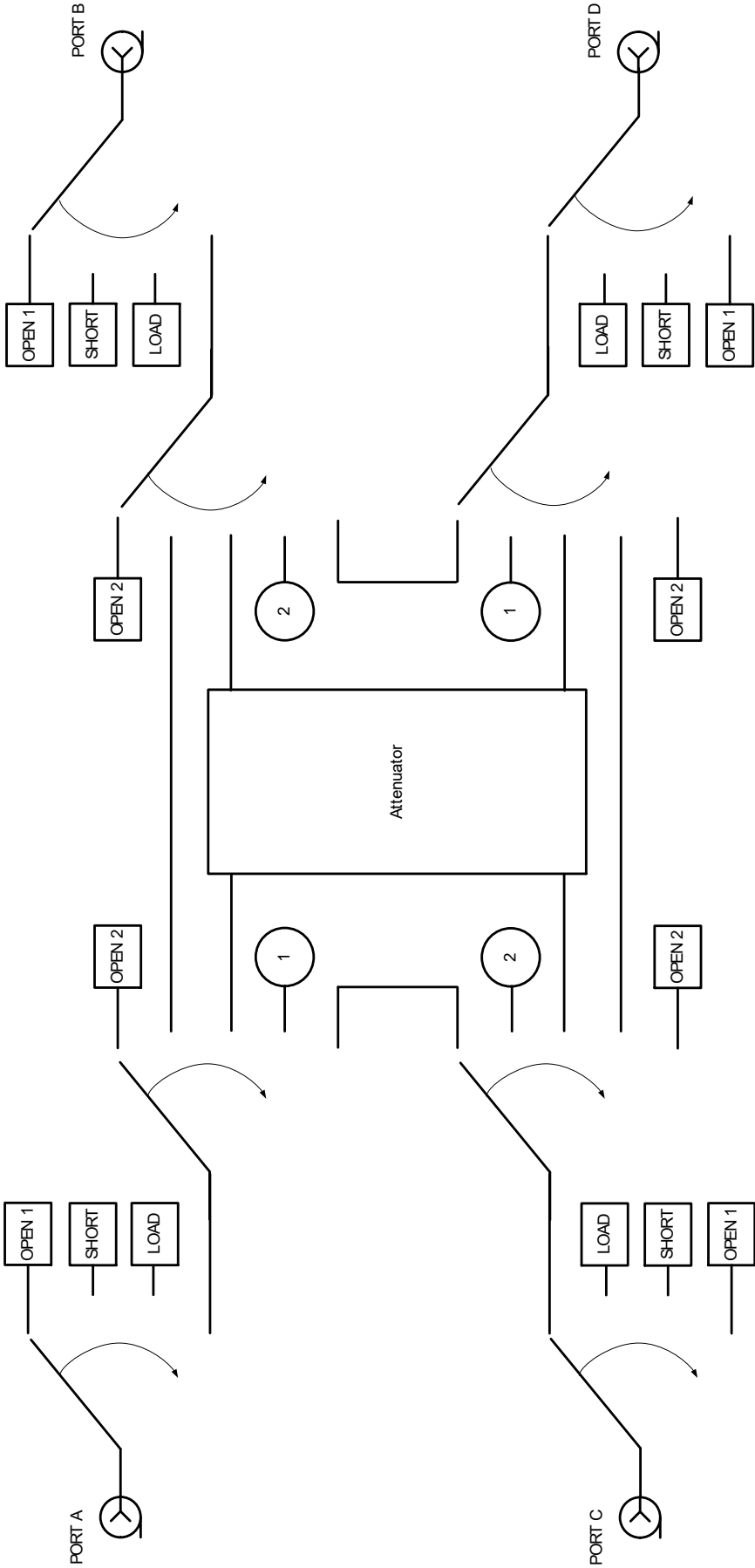

Figure 2.5 Block diagram of ACM8400T and ACM4509

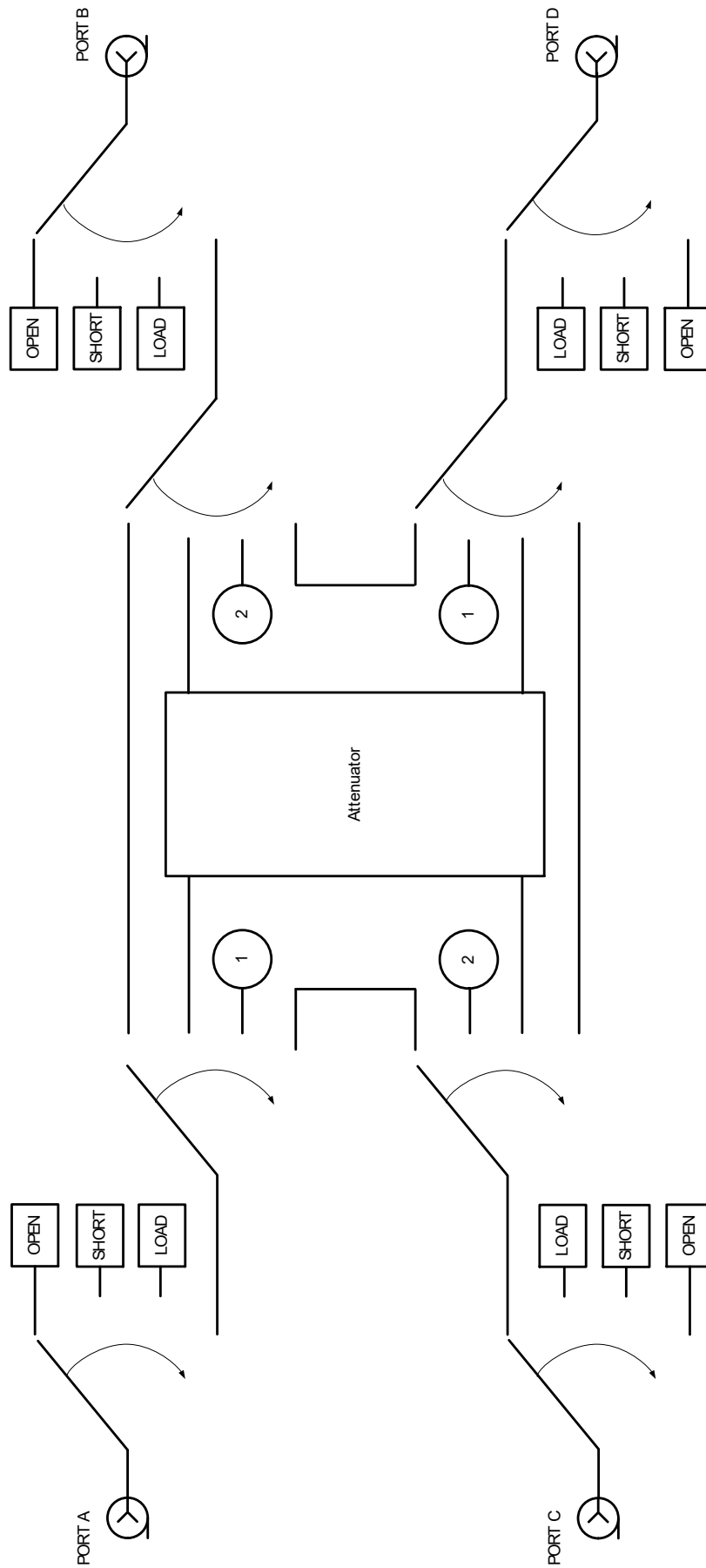

Figure 2.6 Block diagram of ACM4520

2.4.1 Types of Calibration Standards

Calibration standard is a physical device with known parameters used for VNA calibration with the purpose of calculating systematic errors and further correcting the measurement results.

OPEN, SHORT and LOAD are the reflection standards, and THRU is the transmission standard (transmission connection).

The Module includes four types of calibration standards:

- OPEN;
- SHORT;
- LOAD;
- THRU.

| Reflection standard | Parameter |
|---------------------|------------------|
| OPEN | Capacitance C |
| SHORT | Inductance L |
| LOAD | Resistance R_H |

2.4.2 Attenuator

The Module features additional attenuator state, which is not used during calibration. The attenuator is used for checking calibration quality using a special confidence check function, which allows comparing the measured S-parameters of attenuator with the parameters stored in the Module memory.

3 PREPARATION FOR USE

3.1 Operating Restrictions

The accuracy of calibration using the Module largely depends on its proper handling while preparing for use. In order to increase the Module service life, keep its connectors clean and undamaged. Dirty or damaged connector can deteriorate accuracy characteristics and materially affect the VNA calibration results.

Before you start operating the Module, you should perform the following activities in order to prevent the Module damage:

- Visually inspect the connectors, the Module housing and the USB cable from the supply package for damages and contamination. In case you detect any foreign particles on the connectors, clean the connectors using the procedure described in section 6.3.2. Do not operate the Module in case you detect any mechanical damage of its connector. Such Module should be discarded in order to prevent its further usage and damage of other good connectors.
- Visually inspect the connectors, which will be connected to the Module, for damages and contamination. In case you detect any foreign particles on the connectors, clean the connectors using the procedure described in section 6.3.2.
- If necessary, gage the connectors using the procedure described in section 6.3.3 for connecting the Module and devices connected to it.

Pay special attention to the connection sequence. Proper connection sequence prevents central and external conductors from damage, ensures maximum measurement results repeatability, and excludes the most common VNA measurement error, i.e. “bad” connection. The recommended connection sequence is shown in section 6.3.4.

The main reason of measurement accuracy deterioration is the change of ambient conditions between the calibration and DUT measurement. The ambient conditions are described in section 6.3.5.

3.2 Unpacking and Repacking

The Module package ensures its protection from environmental or mechanical damage during handling, transportation and storage.

Consumer package is used for packing the Module. The individual consumer package is a corrugated cardboard box with cushioning inserts.

3.2.1 Unpacking

Unpack the Module in the following order:

- Place the box in accordance with the handling marks.
- Open the box and carefully remove the Module, the USB cable, the USB flash drive and operating manuals.

- Perform visual inspection:
 - The Module housing has to be free from deep scratches and dents, rust and stains from liquid or aggressive vapor. The paint coating and marking must be intact.
 - Visually inspect connectors of all devices for damages and contamination.
 - Check the mating plane and conductor surfaces of connectors for mechanical damage (dents, deep scratches, worn plating etc.).
 - Check the USB cable for damages.
- Save the cardboard box and cushioning inserts for further possible use (storage or shipment for repair).

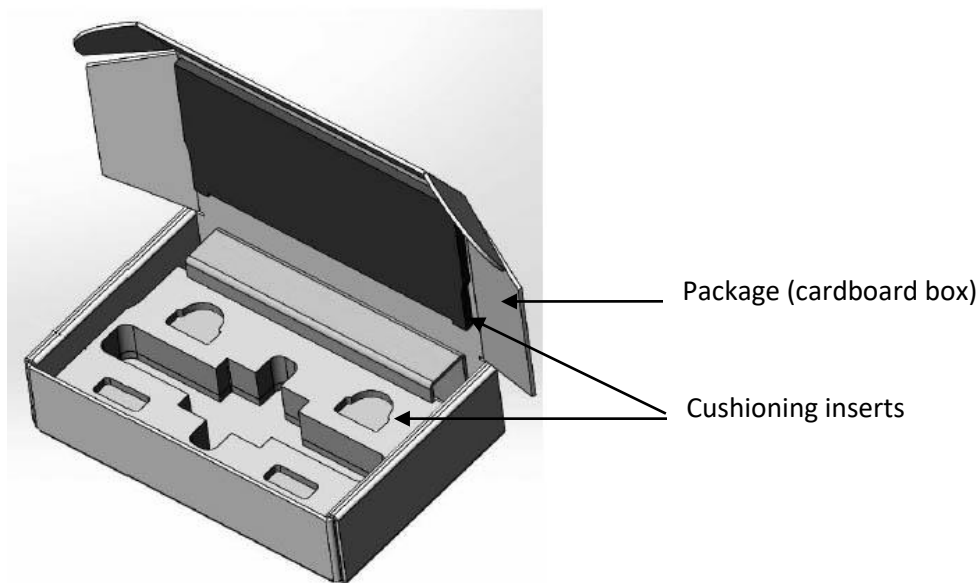

Figure 3.1 Package

3.2.2 Packing

Packing must be done in the closed building with ambient air temperature of no less than 15 °C and relative air humidity of up to 80 %.

Before packing, perform the visual inspection:

- If packing is done before storage, the Module housing has to be free from deep scratches and dents, rust and stains from liquid or aggressive vapor. The paint coating and marking must be intact.
- Visually inspect connectors for damages and contamination.
- Check the mating plane and conductor surfaces of connectors for mechanical damage (dents, deep scratches, worn plating etc.).
- Check the USB cable for damages.

Packing must be performed in the following procedure:

3 PREPARATION FOR USE

- Place the Module in the cardboard box with special cushioning inserts.

| | |
|------|---|
| Note | You can use other material enabling the Module fixation in the box and preventing it from corrosion as cushioning material filling the space between the sides of the box and the Module. |
|------|---|

- Place the cable.
- Close the box. Make sure that the box cover can be easily opened and closed.

3.3 Installation

Unpack the Module and place the Module at the work place.

Take necessary activities to protect against electrostatic discharge at the work site.

In case the Module was stored at the ambient conditions other than the operating conditions, keep the Module in the operating conditions for no less than two hours.

Connect the Module using the USB cable. Warm the Module up for no less than 15 minutes. The procedure of Module connection for warming up is shown in figure 3.2.

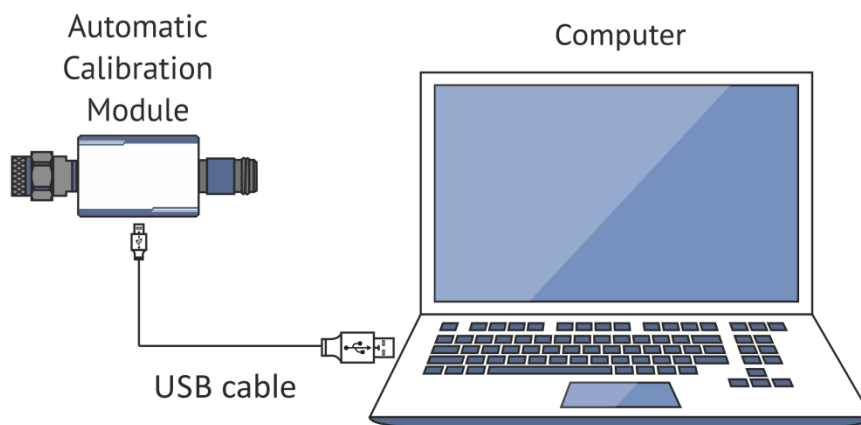

Figure 3.2 Module connection to PC

Typical Module connection diagrams for VNA calibration are shown in section 4.3.

3.4 Software

The Module is controlled by the Copper Mountain Technologies VNA software. Minimum technical requirements to the PC and the description of software installation are described in the VNA Operating Manual.

The VNA software automatically detects the connected Module and makes the *Autocalibration* menu available. Generally, you do not need to select the Module.

If the menu is not active:

3 PREPARATION FOR USE

- Shut down all the started VNA software instances;
- Disconnect the Module from the USB cable for one minute, then restore the USB cable connection;
- Restart the VNA software, make sure that the VNA software functions properly according to the VNA Operating Manual;
- Connect the Module again, make sure that the model and serial number are in compliance with the Module connected.

Driver installation

The USB driver is automatically installed during the first connection of the Module to the USB port.

4 OPERATION PROCEDURE

4.1 Front Panel

Front panels of different models are shown in figures 4.1 – 4.10.

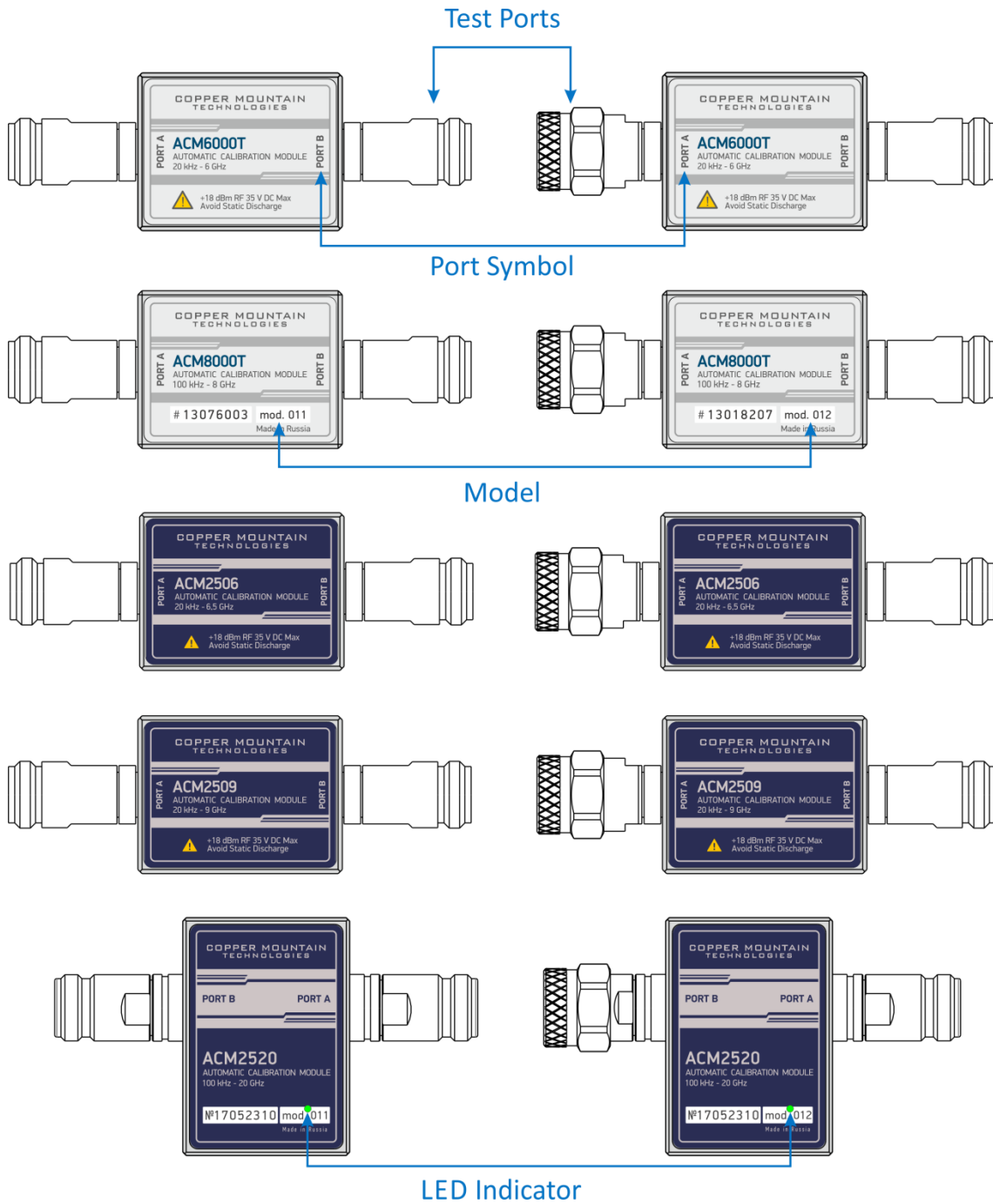

Figure 4.1 Appearance of hardware configuration 011

Figure 4.2 Appearance of hardware configuration 012

4 OPERATION PROCEDURE

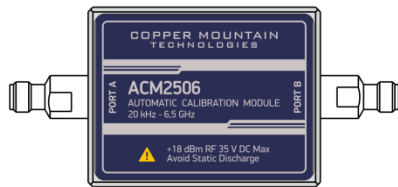
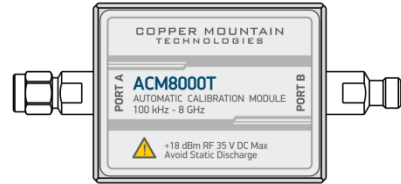
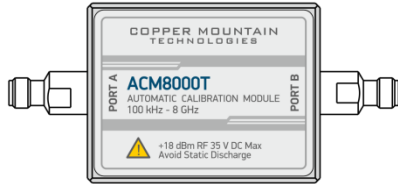
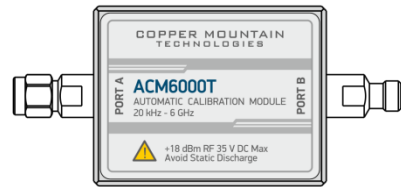
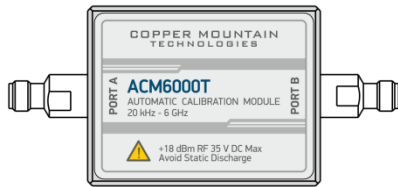

Figure 4.3 Appearance of hardware configuration 111

Figure 4.4 Appearance of hardware configuration 112

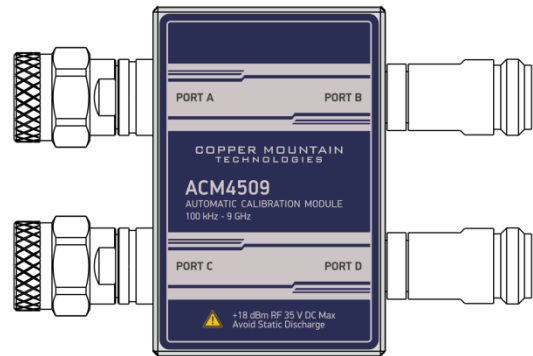
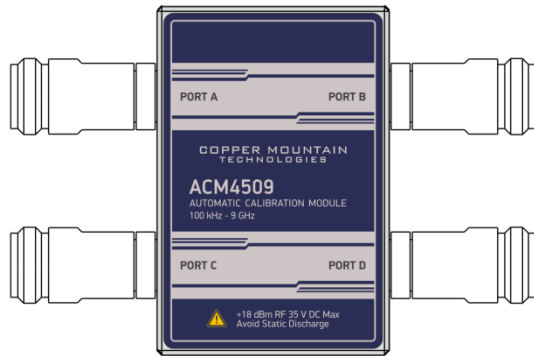
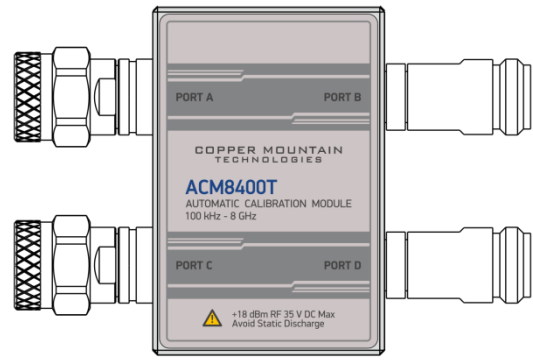
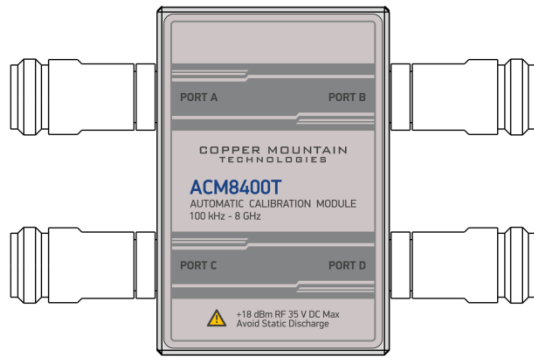

Figure 4.5 Appearance of hardware configuration 01111

Figure 4.6 Appearance of hardware configuration 01212

4 OPERATION PROCEDURE

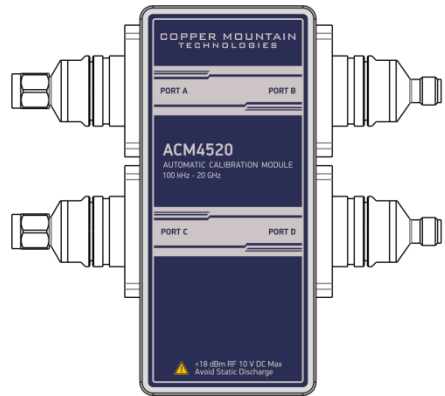
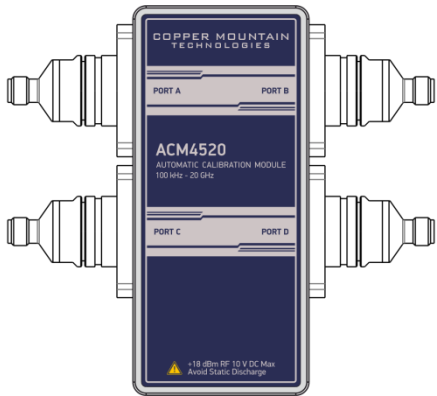
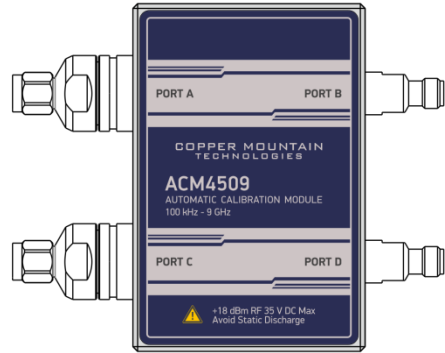
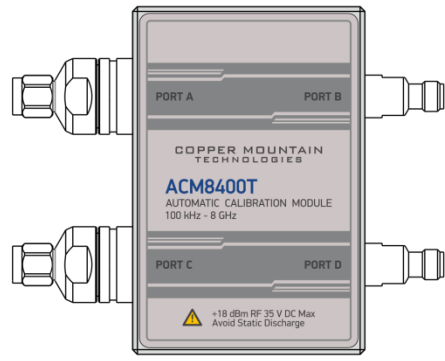
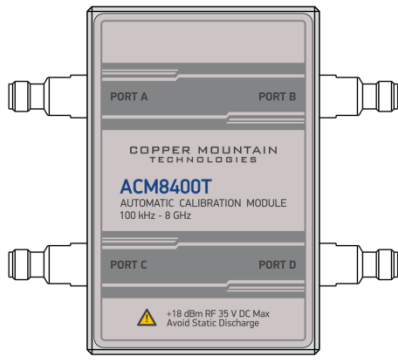

Figure 4.7 Appearance of hardware configuration 11111

Figure 4.8 Appearance of hardware configuration 11212

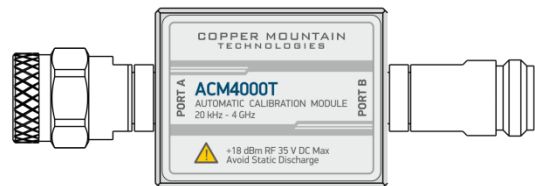
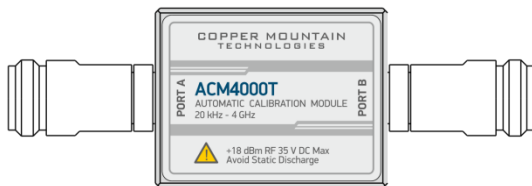

Figure 4.9 Appearance of hardware configuration 511

Figure 4.10 Appearance of hardware configuration 512

4.1.1 Test Ports

The test ports are designed for connecting to VNA being calibrated. The VNA connectors, the cross sections of which were calibrated, are referred to as its test ports.

The Modules connectors are shown in figures 4.11 – 4.16.

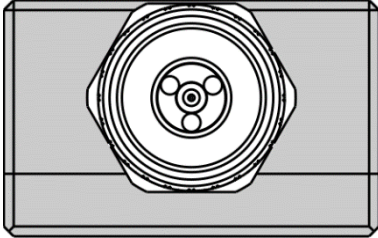

Figure 4.11 Type N, male

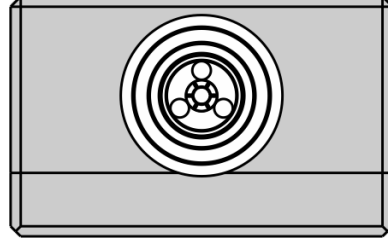

Figure 4.12 Type N, female

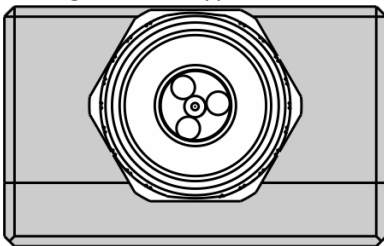

Figure 4.13 Type N (75 Ohm), female

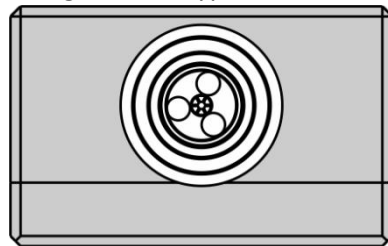

Figure 4.14 Type N (75 Ohm), female

4 OPERATION PROCEDURE

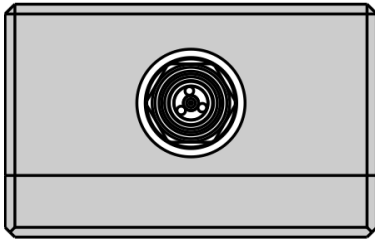

Figure 4.15 3.5 mm, male

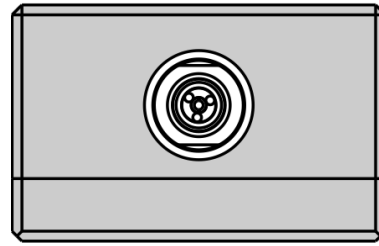

Figure 4.16 3.5 mm, female

4.1.2 LED Status Indicator



The LED indicates the following statuses:

- Flashing green LED indicator – the Module connection to controlling PC.
- Red LED indicator – warm-up mode of the Module. The time required for operating mode setting is automatically counted from the moment of the Module connection using USB. If you disconnect the Module during setting and connect it again, then the counter starts from the beginning.

Additional red LED may indicate the Module connection loss with the PC. In this case, check the Module connection with software (the *Autocalibration* softkey should be active), if there is no connection, disconnect the USB cable from the Module and repeat the connection.

- Green LED indicator – the Module is ready for operation.

Note

The LED indicator is available at ACM2520, ACM8400T, ACM4509 and ACM4520 Modules.

4.2 Side Panel

4.2.1 Mini USB Connector

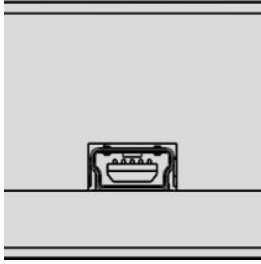

The mini USB connector is located at the side panel of the Module and is intended for the Module connection to the controlling PC. The Module is powered using the USB cable.

Note

The mini USB connector is available at ACM6000T, ACM8000T, ACM2506, ACM2509, ACM8400T, ACM4509 and ACM4000T Modules.

4.2.2 USB B Connector

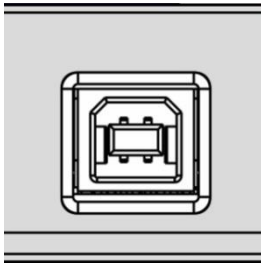

The USB B connector is located at the side panel of the Module and is intended for the Module connection to the controlling PC. The Module is powered using the USB cable.

Note

The USB B connector is available at the ACM2520 and ACM4520 Modules.

4.3 Connection Diagrams

4.3.1 Full One-Port Calibration

In order to perform calibration, it is recommended to connect a LOAD to a free port of the Module. The LOAD is not included in the supply package.

Typical connection diagram for full one-port calibration is shown in figure 4..

To prevent the cable from damage and improve the stability, it is recommended to use additional protection metrology-grade adapters (these adapters are not shown in figure).



Use a torque wrench to tighten the male connector nut. Use a spanner to prevent the connected devices from rotation.

4 OPERATION PROCEDURE

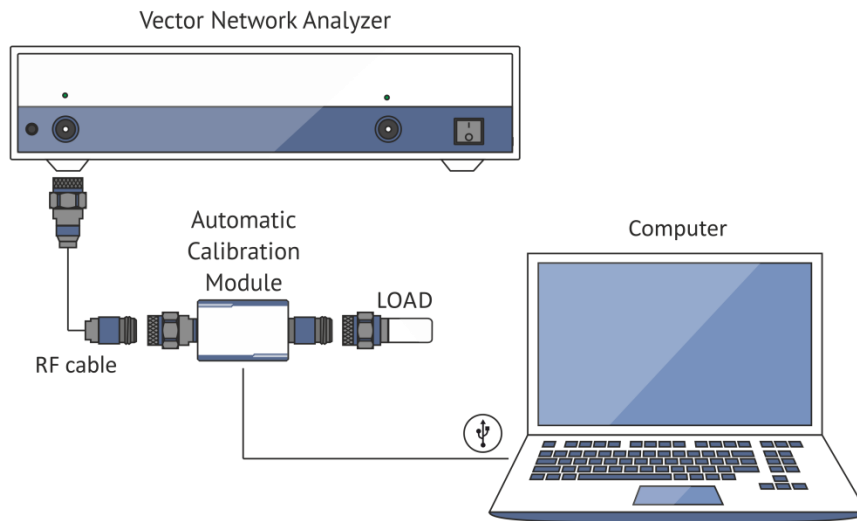

Figure 4.17 Module connection diagram for performing full one-port calibration

4.3.2 One-Path Two-Port and Full Two-Port Calibration

Typical connection diagram for one-path two-port and full two-port calibration is shown in figures 4..

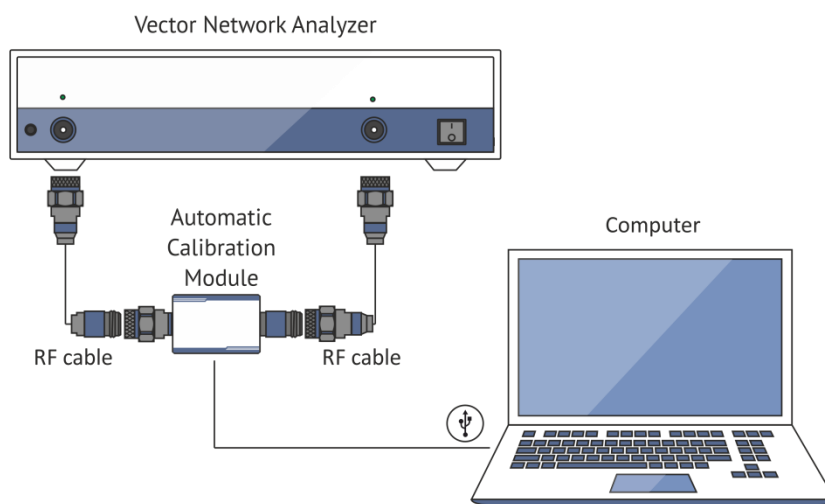

Figure 4.18 Module connection diagram for performing one-path two-port and full two-port calibration

4.3.1 Full Three-Port Calibration

In order to perform calibration, it is recommended to connect a LOAD to a free port of the Module.

Typical connection diagram for performing full three-port calibration is shown in figure 4..

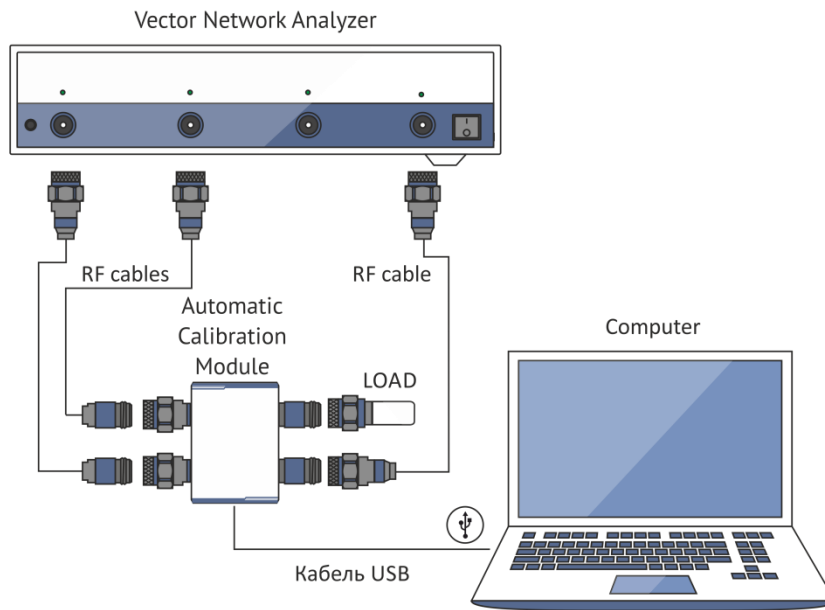

Figure 4.19 Module connection diagram for performing full three-port calibration using ports 1, 2 and 4

4 OPERATION PROCEDURE

4.3.2 Full Four-Port Calibration

Typical connection diagram for performing full four-port calibration is shown in figure 4..

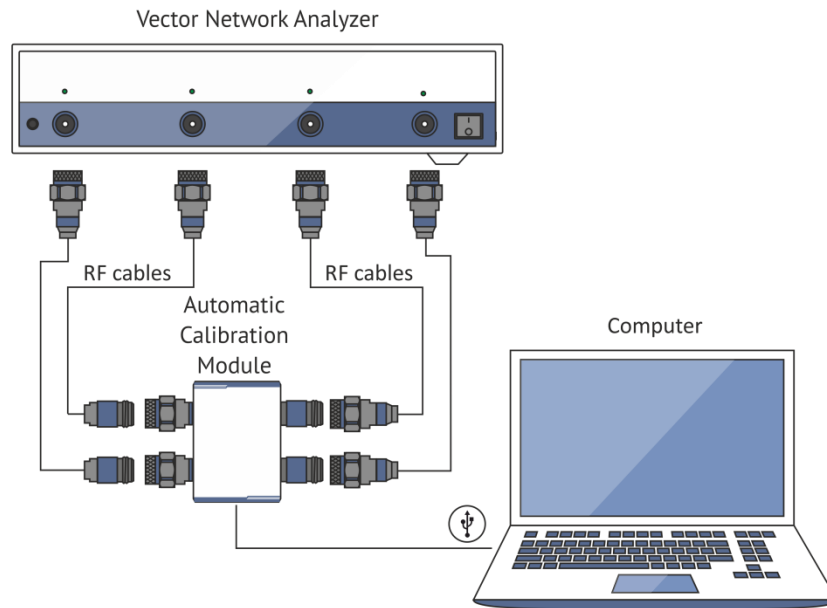

Figure 4.20 Module connection diagram for performing full four-port calibration

4.4 Module Work Session

This section includes the example of the Module work session. Perform the following activities to calibrate all types of VNAs:

- Locate the Module at the work site and warm it up for at least 15 minutes.
- Set up the VNA parameters, at which calibration and DUT parameters measurement will be performed.
- Assemble a test setup.
- Connect the Module (typical connection diagrams are shown in section 4.3).
- Perform the required calibration.
- Disconnect the Module and connect the DUT in its place.

4.4.1 Module Preparation for Calibration

Locate the Module at the work place, switch on and warm up for at least the period of time indicated in the datasheet. If the model used is equipped with an LED status indicator, wait until the LED is green.



The technical specifications will correspond to the stated specifications only after the operating mode setup time is over.

| | |
|-----------------------------|---|
| Module readiness indication | The VNA software can automatically detect the connected Module. After the Module connection, the VNA software makes the <i>Autocalibration</i> menu available. |
|-----------------------------|---|

4.5 Parameters Setting

Before starting measurements and calibration, make sure to set up the following VNA parameters:

- Set up default parameters;
- Select the traces and assign measured S-parameters to them;
- Set up the frequency range and the number of frequency points;
- Set up the output power level of no more than -5 dBm;
- Set up the IF bandwidth.

These parameters are set up in the VNA software. The setting procedure is described in detail in the VNA Operating Manual.

5 CALIBRATION

5.1 Measurement Errors

Different measurement errors affect the results of S-parameters measurement using the VNA. The measurement errors can be divided into two categories:

- Systematic errors, and
- Random errors.

Random errors comprise such errors as noise fluctuations and thermal drift in electronic components, changes in the mechanical dimensions of cables and connectors subject to temperature drift, repeatability of connections and cable bends. Random errors are unpredictable and hence cannot be estimated and eliminated in calibration. Certain measures can be taken to reduce the random error:

- proper source power selection;
- narrower IF bandwidth;
- constant ambient temperature;
- proper warm-up time;
- careful handling of connectors;
- fewer cable bends after calibration;
- usage of torque wrench to tighten the male connector nut and spanner to prevent the connected devices from rotation.

Systematic errors are the errors induced by non-ideality of test setup components. They are repeatable, and their characteristics do not change in time. Systematic errors can be calculated, and their value can be reduced mathematically by measurement results correction.

5.2 Calibration Types

The Modules enable three types of calibration:

- Full one-port calibration;
- One-path two-port calibration;
- Full two-port calibration.

Four-port Modules additionally enable two types of calibration:

- Full three-port calibration;
- Full four-port calibration.

The calibration procedure is described in section 5.5.

5.2.1 Full One-Port Calibration

The three calibration standards are measured in the process of this calibration:

- SHORT;
- OPEN;
- LOAD.

Full one-port calibration features high accuracy.

5.2.2 One-Path Two-Port Calibration

One-path two-port calibration combines full one-port calibration and extended transmission normalization. This calibration type features higher accuracy of measuring frequency response flatness compared to transmission normalization.

One-path two-port calibration requires connection of three calibration standards to the source port as in one-port calibration, as well as connection of the THRU calibration standard between the calibrated source port and the receiver port.

5.2.3 Full Two-Port Calibration

Full two-port calibration requires connection of seven calibration standards: two of each OPEN, SHORT and LOAD calibration standards, and a two-port THRU calibration standard. Such calibration type combines two one-port calibrations for each test port with measurement of transmission and reflection of a THRU standard in both directions.

Full two-port calibration features high accuracy.

5 CALIBRATION

5.2.1 Full Three-Port Calibration

Full three-port calibration requires connection of 12 calibration standards. It combines full one-port calibrations for each test port with measurement of transmission and reflection of a THRU standard in both directions for each couple of ports.

Full three-port calibration features high accuracy for three-port measurements.

5.2.2 Full Four-Port Calibration

Full four-port calibration requires connection of 18 calibration standards. It combines full one-port calibrations for each test port with measurement of transmission and reflection of a THRU standard in both directions for each couple of ports.

Full three-port calibration features high accuracy for four-port measurements.

5.2.3 Unknown Thru

Unknown thru is used in process of full two-, three-, and four-port calibration. The calibration type with an unknown thru is called SOLR, which refers to Short, Open, Load, Reciprocal.

Any arbitrary reciprocal two-port device with unknown parameters can be used as an unknown thru.

There are two basic requirements to the unknown thru:

- The first requirement applies to the transmission coefficient of the THRU. It should satisfy the reciprocity condition ($S_{21} = S_{12}$), which holds for almost any passive network. Furthermore, it is not recommended to use a THRU with the loss higher than 20 dB as it can reduce the calibration accuracy.
- The second requirement is knowledge of the approximate electrical length of the UNKNOWN THRU within an accuracy of 1/4 of the wavelength at the maximum calibration frequency. This requirement, however, can be omitted if the following frequency step size condition is met:

$$\Delta F < \frac{1}{4 \cdot \tau_0},$$

where τ_0 is a delay of reciprocal two-port device.

In this case, the VNA software can automatically determine electrical length (delay) of a reciprocal two-port device.

A thru, implemented inside the Module using an electronic switch, features loss. That is why, it is necessary to know exact thru parameters or use an unknown thru algorithm in order to obtain the required calibration accuracy.

The Module allows using both of these variants. Its memory stores S-parameters of the thru which are used for calculation of calibration coefficients. The above parameters are not used if the unknown thru algorithm is applied.

5.3 Module Advantages

Calibration involving the Module has a number of advantages compared to conventional calibration with a kit of mechanical calibration standards:

- Only one connection required;
- Reduced calibration time;
- Less probability of operator's mistakes;
- Less wear of VNA test ports connectors.

5.4 Thermal Compensation

Thermal compensation is a software function of Module parameters correction using the data of internal temperature sensor and data on temperature dependence.

The Module temperature dependence data are the thermal compensation coefficients of magnitude and phase of reflection or transmission coefficients for different Module states stored in its memory.

The compensated magnitude value M_c , dB, is calculated using the following formula:

$$M_c = M \times k_m \times (T_{char} - T),$$

where:

M – magnitude before compensation, dB;

k_m – thermal compensation coefficient magnitude, dB/°C;

T_{char} – temperature at Module characterization, °C;

T – current temperature inside the Module housing, °C.

Compensated phase value, P_c °, is calculated using the following formula:

$$P_c = P \times k_p \times (T_{char} - T),$$

where:

P – phase value before compensation, °;

k_p – thermal compensation coefficient phase, °/°C;

T_{char} – temperature at Module characterization, °C;

T – current temperature inside the Module housing, °C.

Temperature dependence of S-parameters of each Module is measured at the factory and stored in its memory.

Thermal compensation can be applied to the factory or user characterization data.

5 CALIBRATION

The user can enable or disable the thermal compensation function.

5.5 Calibration Procedure

Calibration is performed in fully automatic mode. The calibration procedure is the following:

- 1) Press the calibration softkey in the software main menu.
- 2) Select automatic calibration in the resulting menu. The autocalibration softkey becomes active after the Module connection (typical connection diagrams are shown in section 4.3).
- 3) Press the characterization softkey.
- 4) Select factory characterization or one of three user characterizations (user characterization procedure is described in section 5.6) in the characterization menu.
- 5) Select the Module orientation method by pressing the orientation softkey.
- 6) Select the unknown thru algorithm state. The unknown thru algorithm can be either enabled or disabled.
- 7) Select the thermal compensation function state. The thermal compensation function can be either enabled or disabled.
- 8) If necessary, display the detailed information on characterization. The information can be displayed by pressing the respective softkey in the autocalibration menu.
- 9) Select the calibration type: one-port, two-port, three-port or four-port.
- 10) Specify the port for full one-port calibration, two ports for full two-port calibration and three ports for full three-port calibration.
- 11) Wait until calibration is completed.

The calibration will be performed automatically: the standards from the Module set will be connected to VNA in sequence under the VNA software control. Then the calibration coefficients table will be calculated and stored in the VNA memory.

When calibration is completed, certain icons will be indicated in the status bars of reflection and transmission coefficients traces:

- [F1] – full one-port calibration;
- [OP] – one-path two-port calibration;
- [F2] – full two-port calibration;
- [F3] – full three-port calibration;
- [F4] – full four-port calibration.

The automatic calibration algorithm is shown in figure 5.1.

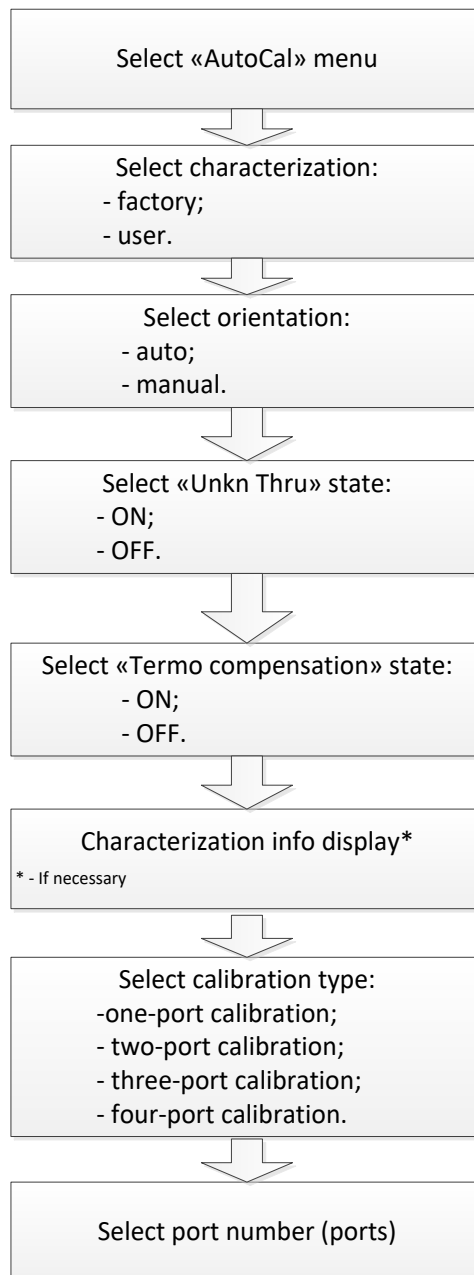

Figure 5.1 Autocalibration algorithm

5 CALIBRATION

Detailed information on calibration using the Module and the names of all softkeys for all VNAs can be found in the VNA Operating Manual.

5.6 User Characterization Procedure

Characterization is the process of calculation of S-parameters table for all Module states.

User characterization of the Module is required if the Module connectors were modified using the adapters. The new device including the Module and adapters is characterized.

Before you perform user characterization of the two-port Module, you need to make the two-port calibration of the VNA with the ports' configuration compatible with the Module port configuration.

Before you perform user characterization of the four-port Module, you need to make the four-port calibration of the VNA with the ports' configuration compatible with the Module port configuration.

The Module is characterized along with its adapters. To save the characterization, do not disconnect and reconnect the adapters which were characterized with the Module. If you disconnect the adapters, you will have to perform user characterization again.

User characterization procedure in the VNA software:

- 1) Press the calibration softkey in the software main menu.
- 2) Select automatic calibration in the resulting menu.
- 3) Press the characterization selection softkey in the autocalibration menu.
- 4) Select one of three user characterizations in the characterization menu.
- 5) Select the Module orientation method by pressing the orientation softkey in the autocalibration menu. It is recommended to use automatic orientation.
- 6) Start the Module characterization by pressing the respective softkey in the autocalibration menu.
- 7) Specify the following information in the pop-up dialog box:
 - Operator's name;
 - VNA model;
 - Characterization location;
 - Connector types;
 - Adapters connector types.
- 8) Press the save softkey to complete the Module user characterization.

The user characterization procedure is shown in figure 5.2.

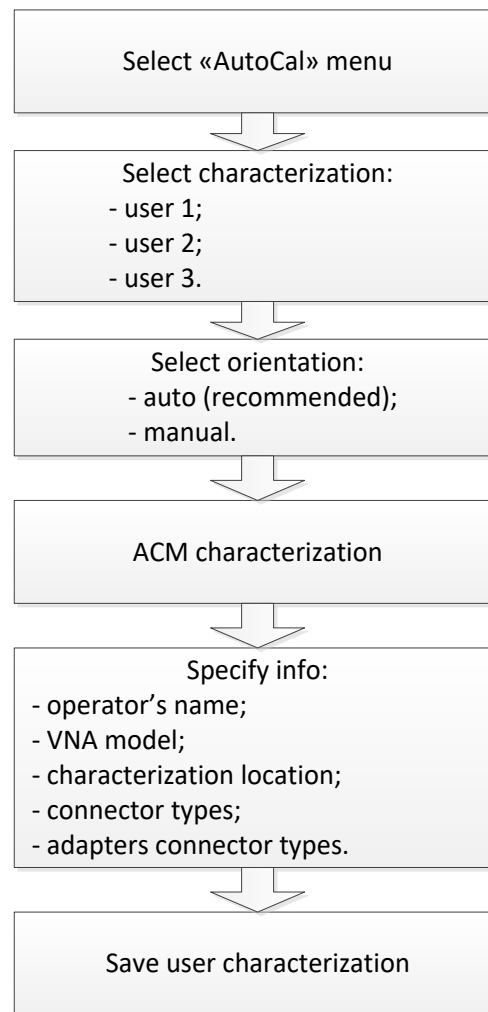

Figure 5.2 User characterization algorithm

Detailed information on the Module user characterization and the names of all softkeys for all VNAs can be found in the VNA Operating Manual.

5.7 Confidence Check

Confidence check is a test of current calibration performed either using the Module or any other method.

The Module features an additional attenuator state, which is not used during calibration. The attenuator is intended for checking calibration by means of a special software function, which enables comparison of measured attenuator S-parameters and the values stored in the Module memory.

5 CALIBRATION

Confidence check procedure:

- 1) Press the calibration softkey in the software main menu.
- 2) Select automatic calibration in the resulting menu.
- 3) Press the characterization selection softkey in the autocalibration menu.
- 4) Select factory characterization or one of three user characterizations in the characterization menu.
- 5) Select the Module orientation method by pressing the orientation softkey in the autocalibration menu. It is recommended to use automatic orientation.
- 6) Press the «Confidence Check» softkey in the autocalibration menu.
- 7) Wait until the confidence check is completed.

The confidence check will be performed automatically. Two traces for each S-parameter will be displayed after measurement. The measured parameters will be indicated on the data trace, and the parameters from the Module memory will be indicated on the memory trace.

Compare the data and memory traces to evaluate whether the calibration was successful. You can also use the function of math operations with memory traces for a finer trace comparison.

Confidence check algorithm is shown in figure 5.3.

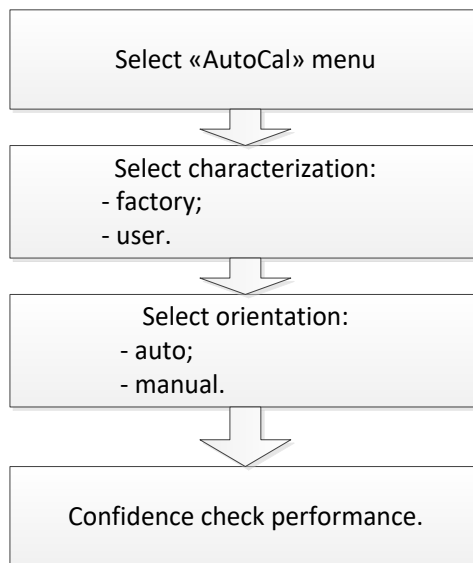

Figure 5.3 Algorithm of confidence check using the Module

Detailed information on the Module confidence check and the names of all softkeys for all VNAs can be found in the VNA Operating Manual.

5.8 Automation

The Module supports remote control using third party software. The control function is implemented by means of USB protocol. The VISA library has to be installed on the PC for interaction. The library allows controlling measuring equipment in almost any programming language, i.e. C/C++, Visual Basic, MATLAB, LabVIEW, etc. The VISA laboratory supports multiple interfaces and protocols, including USBTMC-USB488 based protocol implemented in the Module.

For detailed information on control functions see the Module Programming Manual.

6 Maintenance

6.1 Introduction

This section establishes the procedure and rules of maintenance enabling constant operational readiness of the Module.

6.2 General Guidelines

The Module maintenance is intended for controlling its performance parameters and securing its service life.

6.3 Maintenance Procedure

6.3.1 Maintenance Activities

The Module maintenance includes the following activities:

- Inspection, and
- Functional test.

The inspection should be done every time before and after the Module is used.

The inspection comprises:

- Checking components against the supply package list.
- Cleaning dust and dirt from external surfaces of the Module. To clean the Module's external surfaces, use dry or slightly wet cloth. Do not clean the Module inside.
- Cleaning connectors as described in section 6.3.2.

Functional test should be carried out once per 100 connections.

The functional test includes:

- Inspection;
- Module connectors gaging as described in section 6.3.3;
- Confidence check.

6.3.2 Cleaning Connectors

Clean the connectors before and after application of the Module.

The procedure of cleaning connectors is the following:

- Wipe the connector surfaces as shown by arrows in figure 6.1 or 6.2 with a swab wetted in alcohol.

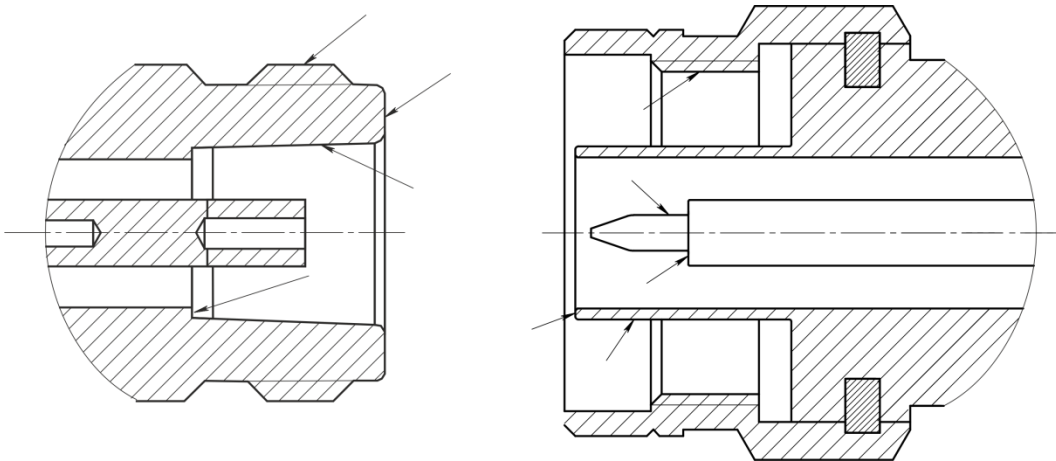

Figure 6.1 Type N connectors

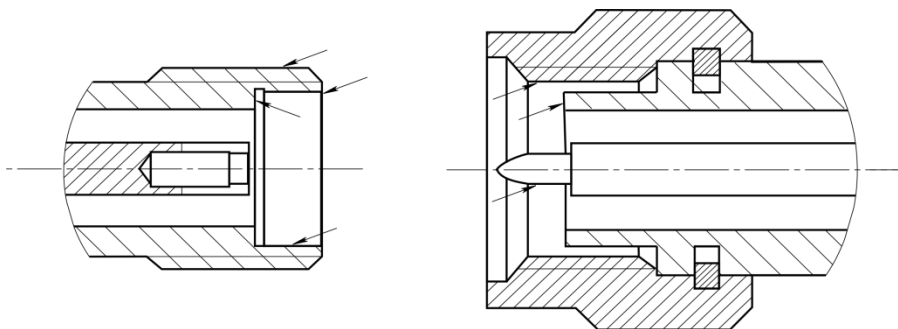

Figure 6.2 3.5 mm connectors

- Use compressed air to clean other internal connector surface.
- Let the alcohol dry on the connector surfaces.
- Visually inspect the connectors to make sure that no particles or residue remain.
- Repeat the cleaning procedure if necessary.



NEVER use metal items for cleaning connectors.

NEVER wipe the center conductors of female connectors. They should be blown with compressed air.

6.3.3 Gaging Connectors

The user should gage the connectors before the first use of the Module and regularly during the operation.

The first gaging of connectors allows obtaining pin depth, which can be used during the Module operation to evaluate its changing.

It is recommended to gage the connectors again if:

- A visual inspection or Module calibration results suggest that the connector may have defects or damages.
- It is detected that the connectors of devices used with the Module are damaged or their pin depth values are out of range for this type of connectors.
- After every 100 connections.

Use gages for coaxial connectors in compliance with their operating instructions or use multi-purpose tools for linear measurements (for example, micrometer, dial indicator, etc.) to gage the connectors.

You need to measure pin depth of PORT A and PORT B connectors and, if available, of PORT C and PORT D connectors during gaging. Only measure the A pin depth of type N connectors (figure 6.3) and 3.5 mm connectors (figure 6.4).

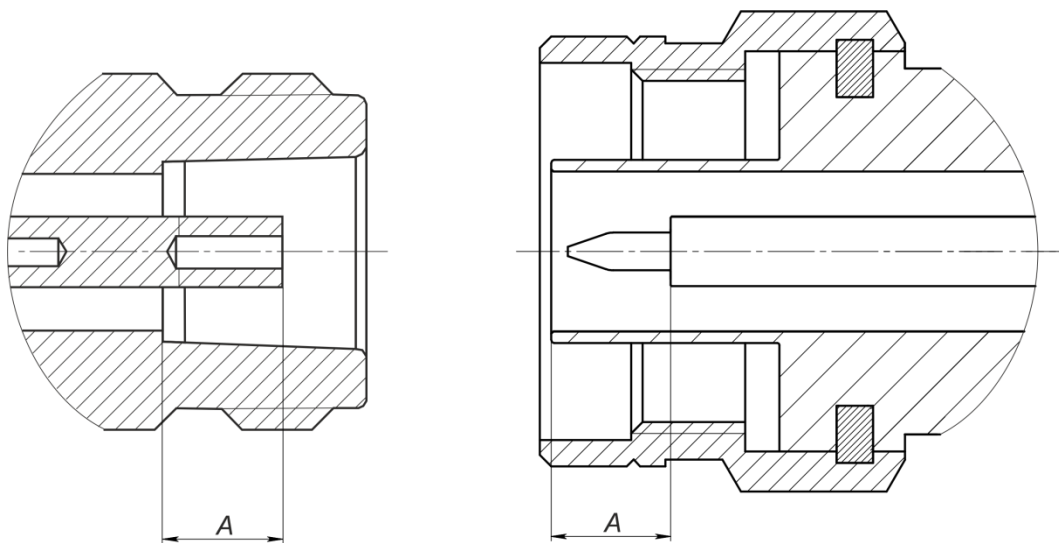

Figure 6.3 Type N connectors (female and male)

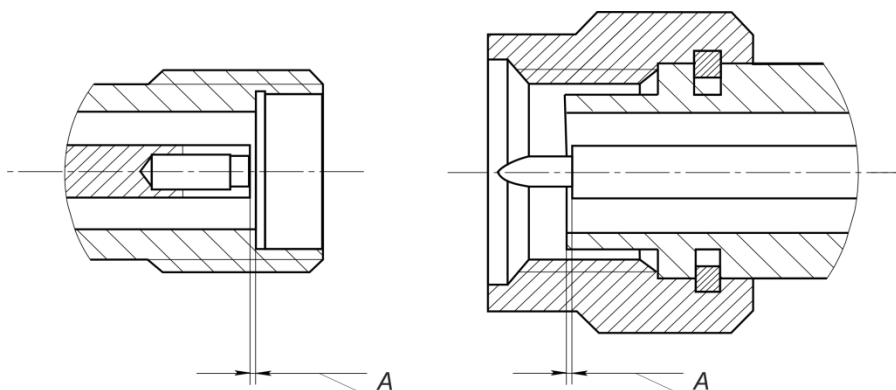

Figure 6.4 3.5 mm connectors (female and male)

The A pin depth value of Module ports connectors must be within the following ranges:

- N, female 5.18 to 5.26 mm
- N, male 5.26 to 5.36 mm
- 3.5 mm, female -0.08 to 0.00 mm
- 3.5 mm, male -0.08 to 0.00 mm

The A pin depth value ranges for connectors of other devices are indicated in their operating manuals.



If the pin depth values of the gaged connectors are out of the specified range, such connectors are subject to repair. The device with such connectors is discarded.

6.3.4 Connecting and Disconnecting Devices

The Module connectors should be connected in the following order:

- Fix the housing of one of the devices being connected. This is necessary to avoid its displacement during connection. You can fix the device by any of the following means:
 - a) by clamps or wrenches;
 - b) by weight or configuration of the device itself;
 - c) by holding the device by hand.
- Carefully align the connectors of the connected devices.
- While holding the device being connected, tighten the male connector nut finger tight. Mating plane surfaces of center conductors and outer conductors have to make uniform light contact as shown in figures 6.5 (for type N connectors) and 6.6 (for 3.5 mm connectors).
- Tighten the male connector nut using the appropriate torque wrench (the torque value depends on the connector type), while holding the device being connected by hand or an open-end wrench to keep it from turning. Finally tighten the male connector nut by holding the wrench at the end of the handle. Tighten the connection just to the torque wrench “break” point.

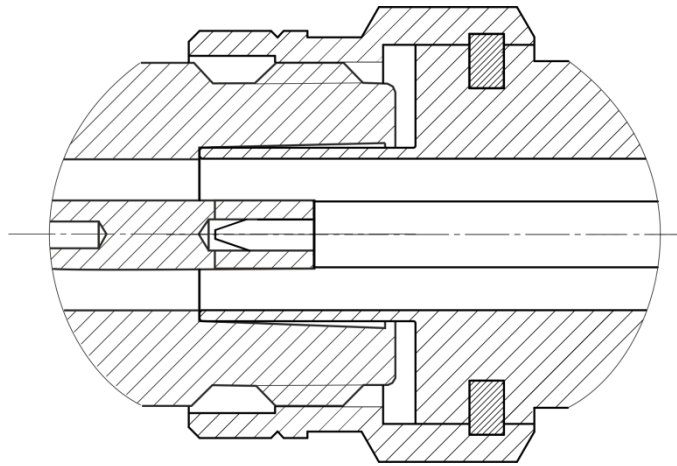

Figure 6.5 Type N connectors (female on the left, and male on the right)

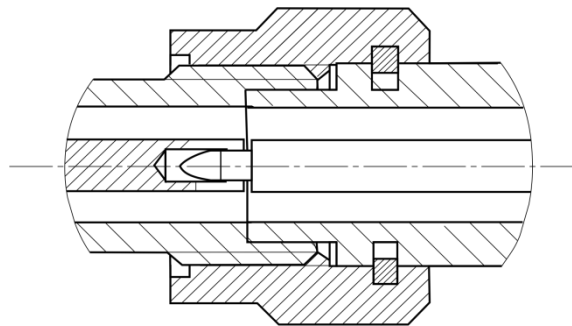

Figure 6.6 3.5 mm connectors (female on the left, and male on the right)

Disconnect the connectors in the following order:

- Using the torque wrench, which was used for tightening, loosen the male connector nut, while holding the device by hand or an open-end wrench to prevent it from turning.
- While holding the device so that the connector's center conductor was at the same straight line as it was connected, turn the male connector nut. Pull the connectors straight apart.

6.3.5 Ambient Conditions Control

The measurement accuracy can be severely affected by the change of environmental conditions (especially ambient temperature) between the VNA calibration and the DUT measurements.

The measurements should be performed at the ambient temperature within ± 1 °C of the temperature at the time VNA calibration.

6.4 Factory Calibration

Factory calibration is a regular procedure performed at precision equipment using a special method. The factory calibration results ensure accurate information on the Module fitness for its intended use.

The calibration should be done once per year. The user may reduce this interval between calibrations in case the Module is used more frequently.

7 Routine Repairs

In case of the Module breakdown, only authorized routine repair or repair by the licensed company is permitted. The repair method is non-differential.

| | |
|-------------------------|--|
| Routine repairs | Repairs performed to enable or restore the device performance, which includes replacement and/or recovery of separate parts. |
| Non-differential method | The method of repairs at which the restored constituent parts do not belong to the specific device instance. |

8 Storage Instructions

Before the first use, store the Module in the factory package at ambient temperature from 0 to +40 °C and relative air humidity up to 80% (at 25 °C).

After you have removed the factory package, store the Module at ambient temperature from +10 to +35 °C and relative air humidity up to 80% (at 25 °C).

Ensure to keep the storage facilities free from dust, fumes of acids and alkalis, aggressive gases, and other chemicals, which can cause corrosion.

9 Transportation

Please load and unload of the Module packages carefully avoiding shock or damage of the package. Use the markings on the package to place the Modules correctly during transportation.

The Modules must be shipped in any closed vehicle at temperature from -50 to +70 0 C, relative humidity 95% (at 30 0 C) and atmospheric pressure of 70 to 106.7 kPa (537 to 800 mm Hg).





The Modules can be shipped in packages in conditions excluding any exposure to mechanical or package damage during transportation.

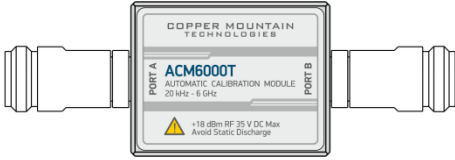
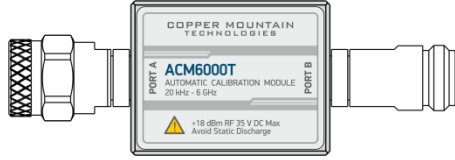
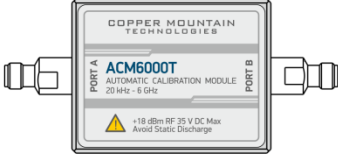
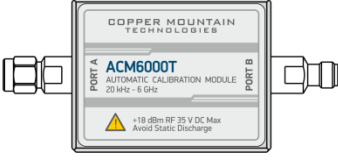

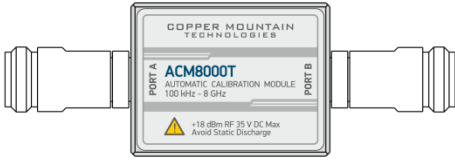
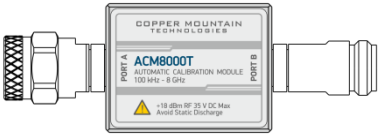
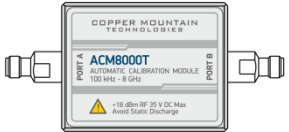
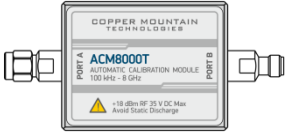

Cargo holds, railway cars, containers, and truck beds, utilized for shipment of the Module should be free from any traces of cement, coal, chemicals, etc. When shipped by air the products should be kept in aircraft sealed compartments.

APPENDIX A
(REFERENCE)
MODULES OVERVIEW

| Module | Frequency range Characterization points Number of ports Port connector | Supported calibrations | Features |
|---|---|--|---|
|  <p>ACM6000T-011</p> | <p>20 kHz to 6 GHz 2 to 1601 2 ports type N (50 Ohm)</p> | <p>Full one-port One-path two-port Full two-port</p> | <p>Unknown thru Thermal compensation User characterization Automatic orientation Confidence check</p> |
|  <p>ACM6000T-012</p> | <p>20 kHz to 6 GHz 2 to 1601 2 ports type N (50 Ohm)</p> | <p>Full one-port One-path two-port Full two-port</p> | <p>Unknown thru Thermal compensation User characterization Automatic orientation Confidence check</p> |
|  <p>ACM6000T-111</p> | <p>20 kHz to 6 GHz 2 to 1601 2 ports 3.5 mm (50 Ohm)</p> | <p>Full one-port One-path two-port Full two-port</p> | <p>Unknown thru Thermal compensation User characterization Automatic orientation Confidence check</p> |
|  <p>ACM6000T-112</p> | <p>20 kHz to 6 GHz 2 to 1601 2 ports 3.5 mm (50 Ohm)</p> | <p>Full one-port One-path two-port Full two-port</p> | <p>Unknown thru Thermal compensation User characterization Automatic orientation Confidence check</p> |

| | | | | |
|---|--------------|---|---|--|
|  | ACM8000T-011 | 100 kHz to 8 GHz 2 to 1601 2 ports type N (50 Ohm) | Full one-port One-path two-port Full two-port | Unknown thru Thermal compensation User characterization Automatic orientation Confidence check |
|  | ACM8000T-012 | 100 kHz to 8 GHz 2 to 1601 2 ports type N (50 Ohm) | Full one-port One-path two-port Full two-port | Unknown thru Thermal compensation User characterization Automatic orientation Confidence check |
|  | ACM8000T-111 | 100 kHz to 8 GHz 2 to 1601 2 ports 3.5 mm (50 Ohm) | Full one-port One-path two-port Full two-port | Unknown thru Thermal compensation User characterization Automatic orientation Confidence check |
|  | ACM8000T-112 | 100 kHz to 8 GHz 2 to 1601 2 ports 3.5 mm (50 Ohm) | Full one-port One-path two-port Full two-port | Unknown thru Thermal compensation User characterization Automatic orientation Confidence check |

| | | | |
|---|--|--|---|
|  | <p>20 kHz to 6.5 GHz 2 to 1601 2 ports type N (50 Ohm)</p> | <p>Full one-port One-path two-port Full two-port</p> | <p>Unknown thru Thermal compensation User characterization Automatic orientation Confidence check</p> |
|  | <p>20 kHz to 6.5 GHz 2 to 1601 2 ports type N (50 Ohm)</p> | <p>Full one-port One-path two-port Full two-port</p> | <p>Unknown thru Thermal compensation User characterization Automatic orientation Confidence check</p> |
|  | <p>20 kHz to 6.5 GHz 2 to 1601 2 ports 3.5 mm (50 Ohm)</p> | <p>Full one-port One-path two-port Full two-port</p> | <p>Unknown thru Thermal compensation User characterization Automatic orientation Confidence check</p> |
|  | <p>20 kHz to 6.5 GHz 2 to 1601 2 ports 3.5 mm (50 Ohm)</p> | <p>Full one-port One-path two-port Full two-port</p> | <p>Unknown thru Thermal compensation User characterization Automatic orientation Confidence check</p> |

| | | | |
|---|--|--|---|
|  <p>ACM2509-011</p> | <p>20 kHz to 9 GHz 2 to 1601 2 ports type N (50 Ohm)</p> | <p>Full one-port One-path two-port Full two-port</p> | <p>Unknown thru Thermal compensation User characterization Automatic orientation Confidence check</p> |
|  <p>ACM2509-012</p> | <p>20 kHz to 9 GHz 2 to 1601 2 ports type N (50 Ohm)</p> | <p>Full one-port One-path two-port Full two-port</p> | <p>Unknown thru Thermal compensation User characterization Automatic orientation Confidence check</p> |
|  <p>ACM2509-111</p> | <p>20 kHz to 9 GHz 2 to 1601 2 ports 3.5 mm (50 Ohm)</p> | <p>Full one-port One-path two-port Full two-port</p> | <p>Unknown thru Thermal compensation User characterization Automatic orientation Confidence check</p> |
|  <p>ACM2509-112</p> | <p>20 kHz to 9 GHz 2 to 1601 2 ports 3.5 mm (50 Ohm)</p> | <p>Full one-port One-path two-port Full two-port</p> | <p>Unknown thru Thermal compensation User characterization Automatic orientation Confidence check</p> |

ACM2520-011



100 kHz to 18 GHz
2 to 1601
2 ports
type N (50 Ohm)

Full one-port
One-path two-port
Full two-port

Unknown thru
Thermal compensation
User characterization
Automatic orientation
Confidence check

ACM2520-012



100 kHz to 18 GHz
2 to 1601
2 ports
type N (50 Ohm)

Full one-port
One-path two-port
Full two-port

Unknown thru
Thermal compensation
User characterization
Automatic orientation
Confidence check

ACM2520-111

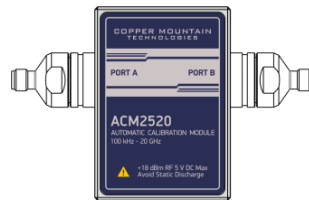

100 kHz to 20 GHz
2 to 1601
2 ports
3.5 mm (50 Ohm)

Full one-port
One-path two-port
Full two-port

Unknown thru
Thermal compensation
User characterization
Automatic orientation
Confidence check

ACM2520-112

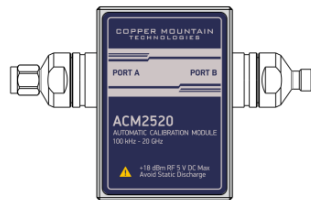

100 kHz to 20 GHz
2 to 1601
2 ports
3.5 mm (50 Ohm)

Full one-port
One-path two-port
Full two-port

Unknown thru
Thermal compensation
User characterization
Automatic orientation
Confidence check

ACM8400T-01111

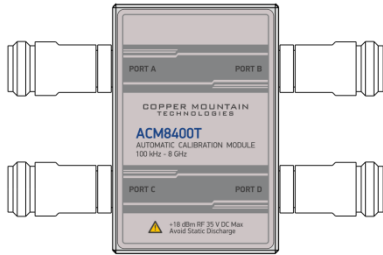

100 kHz to 8 GHz
2 to 1601
4 ports
type N (50 Ohm)

Full one-port
One-path two-port
Full two-port
Full three-port
Full four-port

Unknown thru
Thermal compensation
User characterization
Automatic orientation
Confidence check

ACM8400T-01212

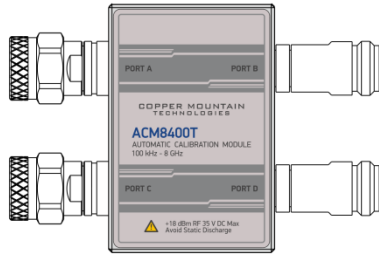

100 kHz to 8 GHz
2 to 1601
4 ports
type N (50 Ohm)

Full one-port
One-path two-port
Full two-port
Full three-port
Full four-port

Unknown thru
Thermal compensation
User characterization
Automatic orientation
Confidence check

ACM8400T-11111

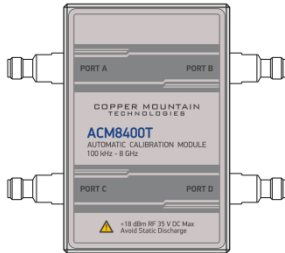

100 kHz to 8 GHz
2 to 1601
4 ports
3.5 mm (50 Ohm)

Full one-port
One-path two-port
Full two-port
Full three-port
Full four-port

Unknown thru
Thermal compensation
User characterization
Automatic orientation
Confidence check

ACM8400T-11212

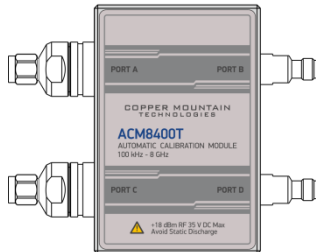

100 kHz to 8 GHz
2 to 1601
4 ports
3.5 mm (50 Ohm)

Full one-port
One-path two-port
Full two-port
Full three-port
Full four-port

Unknown thru
Thermal compensation
User characterization
Automatic orientation
Confidence check

ACM4509-01111

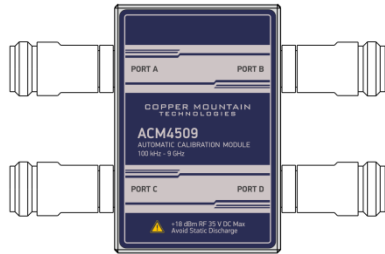

100 kHz to 9 GHz
2 to 1601
4 ports
type N (50 Ohm)

Full one-port
One-path two-port
Full two-port
Full three-port
Full four-port

Unknown thru
Thermal compensation
User characterization
Automatic orientation
Confidence check

ACM4509-01212

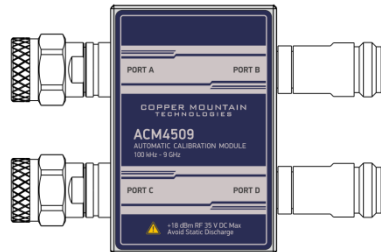

100 kHz to 9 GHz
2 to 1601
4 ports
type N (50 Ohm)

Full one-port
One-path two-port
Full two-port
Full three-port
Full four-port

Unknown thru
Thermal compensation
User characterization
Automatic orientation
Confidence check

ACM4509-11111

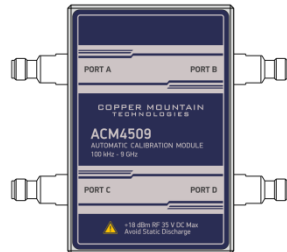

100 kHz to 9 GHz
2 to 1601
4 ports
3.5 mm (50 Ohm)

Full one-port
One-path two-port
Full two-port
Full three-port
Full four-port

Unknown thru
Thermal compensation
User characterization
Automatic orientation
Confidence check

ACM4509-11212

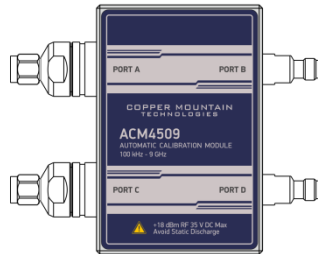

100 kHz to 9 GHz
2 to 1601
4 ports
3.5 mm (50 Ohm)

Full one-port
One-path two-port
Full two-port
Full three-port
Full four-port

Unknown thru
Thermal compensation
User characterization
Automatic orientation
Confidence check

ACM4520-01111



100 kHz to 20 GHz
2 to 1601
4 ports
type N (50 Ohm)

Full one-port
One-path two-port
Full two-port
Full three-port
Full four-port

Unknown thru
Thermal compensation
User characterization
Automatic orientation
Confidence check

ACM4520-01212

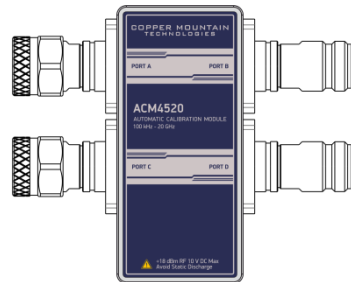

100 kHz to 20 GHz
2 to 1601
4 ports
type N (50 Ohm)

Full one-port
One-path two-port
Full two-port
Full three-port
Full four-port

Unknown thru
Thermal compensation
User characterization
Automatic orientation
Confidence check

ACM4520-11111

100 kHz to 20 GHz
2 to 1601
4 ports
3.5 mm (50 Ohm)

Full one-port
One-path two-port
Full two-port
Full three-port
Full four-port

Unknown thru
Thermal compensation
User characterization
Automatic orientation
Confidence check

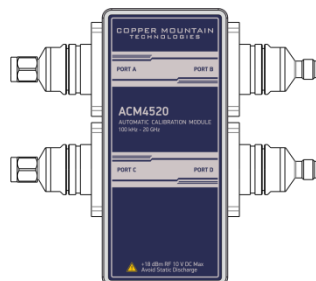
ACM4520-11212

100 kHz to 20 GHz
2 to 1601
4 ports
3.5 mm (50 Ohm)

Full one-port
One-path two-port
Full two-port
Full three-port
Full four-port

Unknown thru
Thermal compensation
User characterization
Automatic orientation
Confidence check

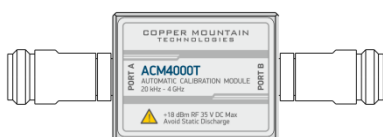
ACM4000T-511

20 kHz to 4 GHz
2 to 1601
2 ports
type N (75 Ohm)

Full one-port
One-path two-port
Full two-port

Unknown thru
Thermal compensation
User characterization
Automatic orientation
Confidence check

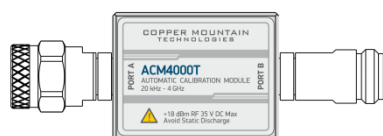
ACM4000T-512

20 kHz to 4GHz
2 to 1601
2 ports
type N (75 Ohm)

Full one-port
One-path two-port
Full two-port

Unknown thru
Thermal compensation
User characterization
Automatic orientation
Confidence check



Germany

Telemeter Electronic GmbH
Joseph-Gaensler-Str. 10, 86609 Donauwoerth
Phone +49 906 70693-0, Fax +49 906 70693-50
info@telemeter.de, www.telemeter.info

Switzerland

Telemeter Electronic GmbH
Romanshornstrasse 117, 8280 Kreuzlingen
Phone +41 71 6992020, Fax +41 71 6992024
info@telemeter.ch, www.telemeter.info

Czech Republic

Telemeter Electronic s.r.o.
České Vrbné 2364, 370 11 České Budějovice
Phone +420 38 5310637, +420 38 5310143
info@telemeter.cz, www.telemeter.info