



Single Phase TC Series Circuit Breakers

Miniature Ambient Compensated

Features

- **Miniature size**
- **Light weight**
- **Trip free**
- **Mil-qualification**
- **Current rating 1-35 amperes**
- **Coordinated ratings**
- **High vibration resistance**
- **High interrupt capacity**



Overview

Klixon® single-phase TC devices are the smallest, lightest aircraft circuit breakers available today. They represent “state-of-the-art” protection for today’s aerospace power systems. Their light weight and small size make them especially well suited for aircraft, avionics and electronic systems.

The Klixon trademark has set the standard for aerospace circuit breakers. Despite the small size, the TC series offers the endurance and reliability required by exacting military specifications, and are available in standard current ratings from 1 – 35 amperes.

Coordination

The 2, 3, 6 and 9TC breaker ratings are coordinated so any rating will trip before another circuit breaker, twice its rating, in the event of a fault of up to 6000 amps let-thru current. This results in improved overall equipment performance, since only the smallest faulted circuit is interrupted, while larger circuits remain operational (see pages 6 and 7 for 6/9TC details).

Ambient Temperature Compensation

Ambient compensated circuit breakers permit system designers to specify smaller gauge wire where the circuit breaker and wiring are exposed to different ambient temperatures. They are especially suited for applications where the ambient temperature exceeds the 160°F maximum of non-ambient compensated thermal circuit breakers. The TC series may be applied where operating temperatures are as high as 250°F (121°C), with no derating of the circuit breaker. This eliminates the need for cooling air and allows substantial weight, space and cost savings.

Options*

- Longer push buttons
- High vibration
- Random vibration
- Metric mounting thread
- Metric terminal thread
- Dust boot†
- Auxiliary switch - male and female contacts available
- Terminal barriers
- Plug-in terminals

Trip Free

The complete line of TC series circuit breakers is trip free. The circuit breaker cannot be maintained closed during an overload even with the actuator button held closed.

High Short Circuit Capacity

For its miniature size, the 2/3TC series offers unusually high current interrupting capacity. Overloads up to 6000 amps at 28 VDC or 2000-3500 amps at 120 VAC, 400 Hz can be safely interrupted without affecting calibration or operating performance in the standard 2/3TC series.

Qualifications

MS3320 - 2TC2
MS3320L - 2TC27
MS3320V - 2TC63
MS14105 - 3TC2
MS14105L - 3TC27
European standards
SAE standards
All U.S. aircraft OEM's
Most European aircraft OEM's

* Contact factory for details

† Part Number 14500-1 Fits 15/32 Bushing
Part Number 14500-5 Fits 7/16 Bushing

Characteristics

2TC14 / 3TC14

2TC14

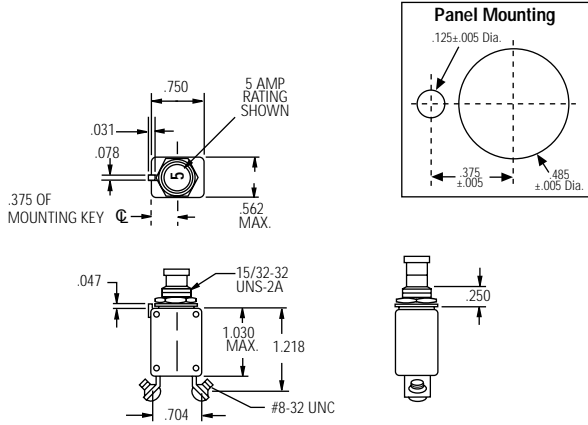

3TC14

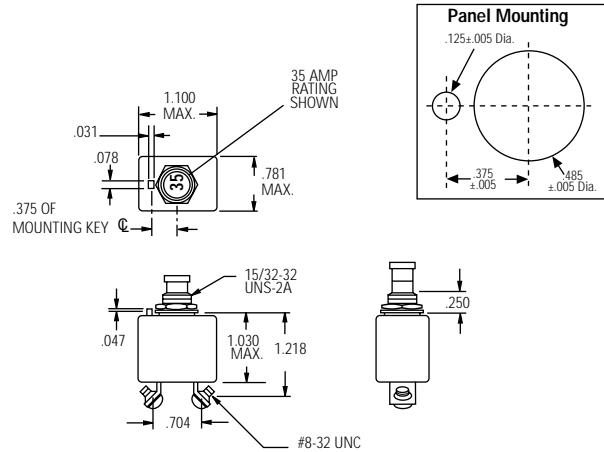

Calibration: 1-25 amps

TEMP °C	MIN ULT TRIP	MAX ULT TRIP	TRIP TIME - SECONDS		
			200%	500%	1000%
+25	115%	138%	4-16	.4-1.6	.10-.40
-54	115%	165%	7-35	.6-3.0	.15-.70
+121	85%	145%	2-13	.25-1.0	.06-.25

Calibration: 15-35 amps

TEMP °C	MIN ULT TRIP	MAX ULT TRIP	TRIP TIME - SECONDS		
			200%	500%	1000%
+25	115%	138%	4-20	.40-1.7	.10-.40
-54	115%	165%	6-35	.55-3.0	.15-.70
+121	85%	145%	2-15	.25-1.0	.06-.25

Vibration*..... 10 G's minimum, 50 - 500 Hz
 Mechanical Shock..... 50 G's
 Acceleration..... 10 G's
 Weight..... 2TC14 - 24 gm max.
 3TC14 - 36 gm max.

Interrupt Current

1-20 amps: 6000 amps at 28 VDC
 25 amps: 1625 amps at 28 VDC
 1-15 amps: 2500 amps at 120 VAC, 400 Hz
 20 amps: 2000 amps at 120 VAC, 400 Hz
 25 amps: 1800 amps at 120 VAC, 400 Hz

Endurance

2500 cycles 120 VAC, 400 Hz Inductive
 5000 cycles 120 VAC, 400 Hz Resistive
 2500 cycles 30 VDC Inductive
 5000 cycles 30 VDC Resistive
 10,000 cycles Mechanical, no load

* Other vibration levels available. Contact factory for details.

TI Number	Voltage Drop (max.)**
2TC14-1	1.10
2TC14-2	0.70
2TC14-2½	0.50
2TC14-3	0.40
2TC14-4	0.45
2TC14-5	0.35
2TC14-7½	0.30
2TC14-10	0.28
2TC14-15	0.25
2TC14-20	0.25
2TC14-25	0.20

TI Number	Voltage Drop (max.)**
3TC14-15	0.25
3TC14-20	0.25
3TC14-25	0.25
3TC14-30	0.25
3TC14-35	0.25

**Max. voltage drop at nominal rated current.

Approximate Time-Current Curves - 2TC and 3TC Circuit Breakers

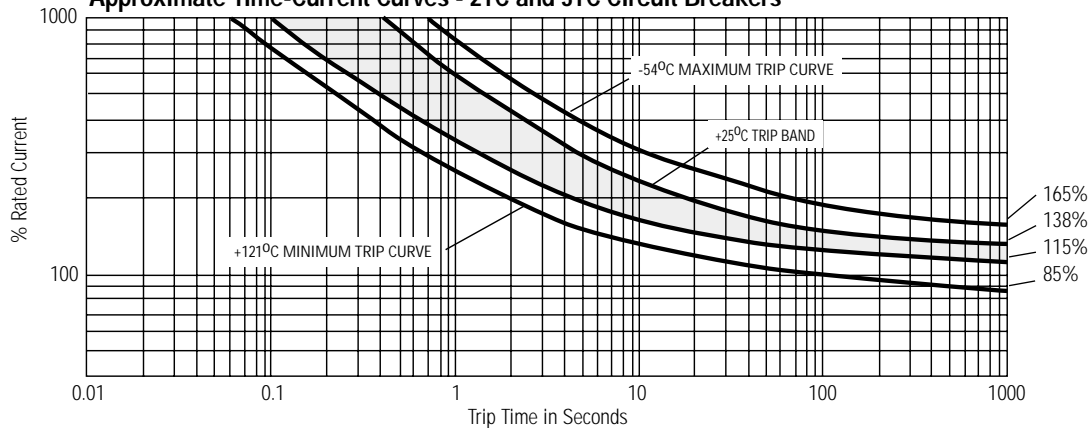

REVISIONS					
ZONE	LTR	2TC2	DESCRIPTION	PROJ. 1041	DATE APPROVED
	AE	SEE ECN		ECN0017504 PAF	8-19-04 D.A.

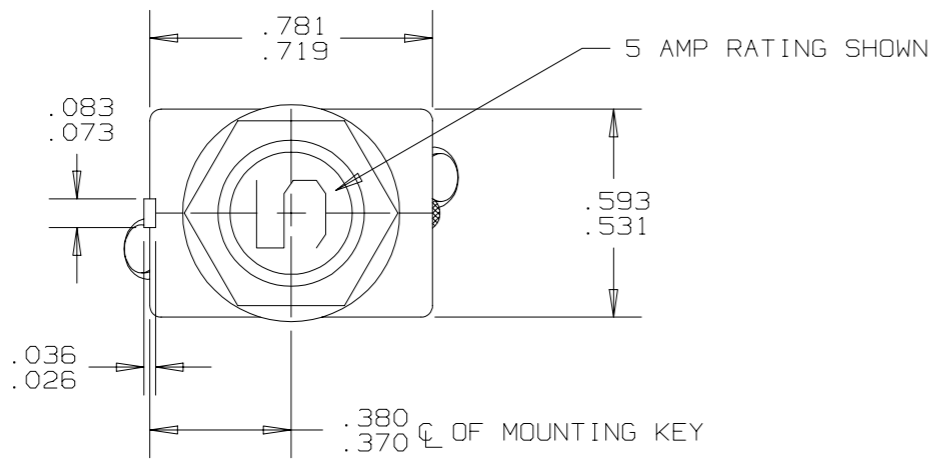

NOTES:

1. EPOXY SURFACES ARE NON-DIMENSIONED. ENVELOPE DRAWING DIMENSIONS DO NOT APPLY TO THESE PROJECTED EPOXY SURFACES.
2. TERMINAL AND MOUNTING HARDWARE MAY BE PACKAGED RATHER THAN INSTALLED
3. COUNTRY OF ORIGIN IS SHOWN FOR ILLUSTRATION PURPOSES ONLY. COUNTRY OF ORIGIN TO BE IDENTIFIED AS REQUIRED.
4. DATE CODE PER 10588-285.
5. MARK IN APPROXIMATE POSITION SHOWN WITH BLACK INK PER 12506-70.

PERFORMANCE CHARACTERISTICS

DETAIL PERFORMANCE PER MIL-C-58096

OVERLOAD CYCLING	-----	100 CYCLES AT 200% RATING
VIBRATION	-----	10 G'S MINIMUM 50-500 HZ
MECHANICAL SHOCK	-----	50 G'S
ACCELERATION	-----	10 G'S
SAND AND DUST	-----	12 HOURS
CORROSION	-----	SALT SPRAY 50 HOURS
HUMIDITY	-----	10 DAYS
EXPLOSION PROOF	-----	WHILE INTERRUPTING RUPTURE CURRENTS

ENDURANCE:	120 VAC	400 HZ INDUCTIVE	2500 CYCLES
	30 VDC	400 HZ RESISTIVE	5000 CYCLES
		INDUCTIVE	2500 CYCLES
		RESISTIVE	5000 CYCLES
		NO LOAD	10000 CYCLES

CALIBRATION:	1 AMP THRU 25 AMP					
		MIN. ULT. TRIP	MAX. ULT. TRIP	200%	500%	1000%
+25°C, +77°F	115% RATING	138% RATING	5-20 SEC.	.5-2.0 SEC.	.12-.53 SEC.	
-55°C, -65°F	115% RATING	160% RATING	7-40 SEC.	.6-3.0 SEC.	.16-.8 SEC.	
+121°C, +250°F	100% RATING	138% RATING	3-13 SEC.	.33-1.1 SEC.	.07-.3 SEC.	

RUPTURE:	1 AMP	120 VAC, 400 HZ	3500 AMPS
	2 AND 2 1/2 AMP	120 VAC, 400 HZ	2800 AMPS
	3 THRU 15 AMP	120 VAC, 400 HZ	2500 AMPS
	20 AMP	120 VAC, 400 HZ	2000 AMPS
	1 THRU 20 AMP	28 VDC	6000 AMPS
	25 AMP	28 VDC	1625 AMPS
	25 AMP	120 VAC, 400 HZ	1800 AMPS

MAXIMUM OPERATING FORCES

PULL OUT	-----	5 LBS. MAX. (22.2 N)
RESET	-----	5 LBS. MAX. (22.2 N)

OPERATING ALTITUDE: 70,000 FT. (21,000 M)

WEIGHT: 25.0 GRAMS MAX.

VOLTAGE DROP:

1 AMP	-----	1.10 VOLTS MAX.
2 AMP	-----	0.70 VOLTS MAX.
2.5 AMP	-----	0.50 VOLTS MAX.
3 AMP	-----	0.40 VOLTS MAX.
4 AMP	-----	0.37 VOLTS MAX.
5 AMP	-----	0.35 VOLTS MAX.
7.5 AMP	-----	0.30 VOLTS MAX.
10 AMP	-----	0.28 VOLTS MAX.
15 AMP	-----	0.25 VOLTS MAX.
20 AMP	-----	0.25 VOLTS MAX.
25 AMP	-----	0.20 VOLTS MAX.

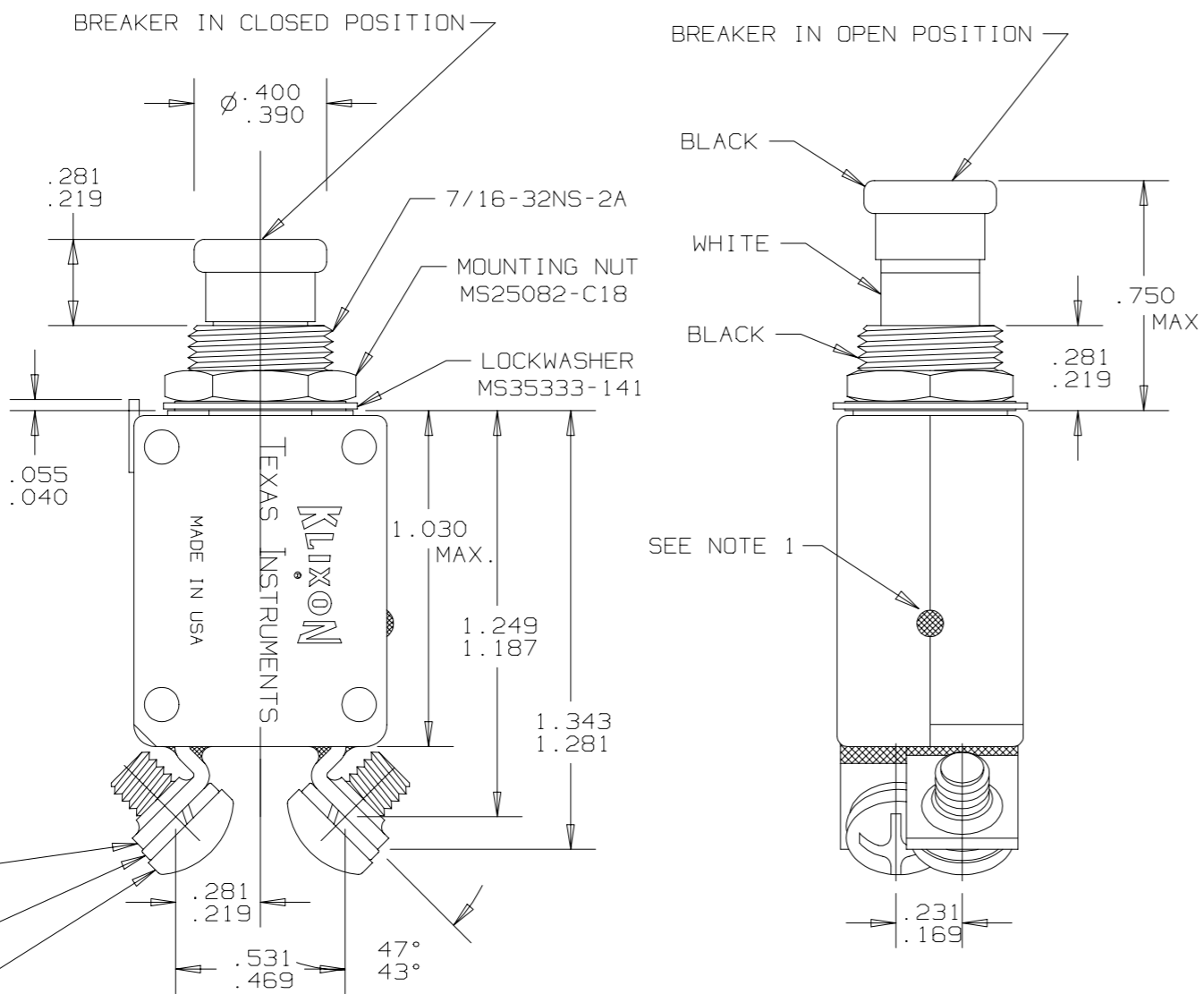

2TC2-25	N/A
2TC2-20	MS 3320-20
2TC2-15	MS 3320-15
2TC2-10	MS 3320-10
2TC2-7 1/2	MS 3320-7 1/2
2TC2-5	MS 3320-5
2TC2-4	MS 3320-4
2TC2-3	MS 3320-3
2TC2-2 1/2	MS 3320-2 1/2
2TC2-2	MS 3320-2
2TC2-1	MS 3320-1
T.I. PART NO.	MS PART NO.

MARKING TABLE

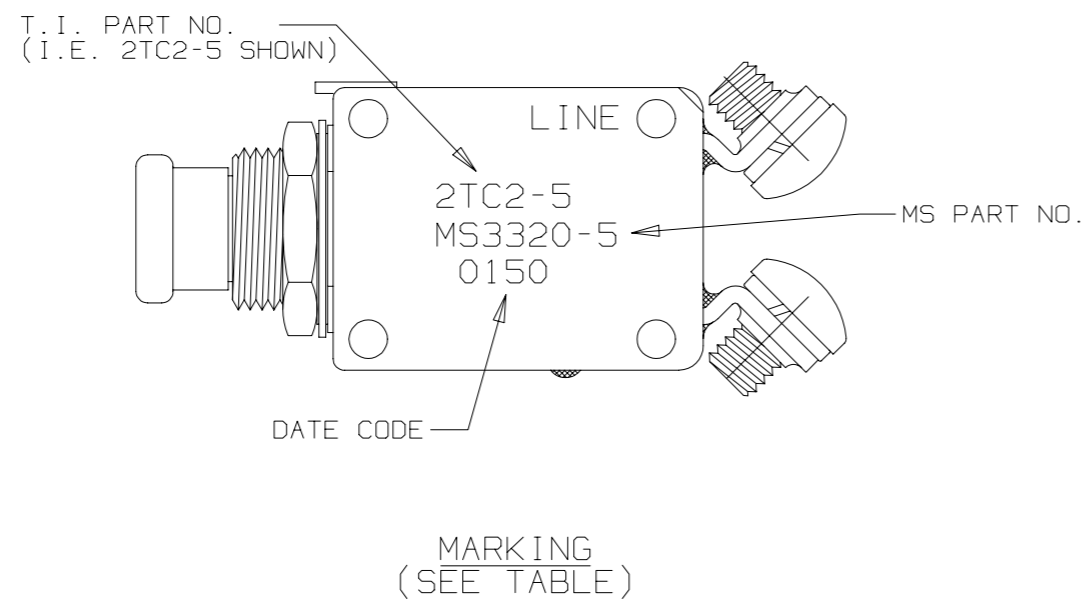

THIS IS A CAD DRAWING. THE GEOMETRY IN THE ASSOCIATED CAD COMPUTER FILE IS DIMENSIONALLY ACCURATE. WHEN DRAWING IS BEING REVISED, THE GEOMETRY MUST BE UPDATED IN ALL VIEWS AND ON ALL SHEETS.

UNLESS OTHERWISE SPECIFIED DIMENSIONS ARE IN INCHES	DRAWN TOM DAIL	DATE 10-30-89	Q3	P2	P18
TOLERANCE ON FRACTIONS DECIMALS ANGLES	ENGINEER JACQUES CHAMMAS	12-4-89	 TEXAS INSTRUMENTS ATTLEBORO, MASSACHUSETTS 02703 CONTROL PRODUCTS DIVISION		
MATERIAL	APPROVED N/A		TITLE PART NO. 2TC2 AMBIENT COMPENSATED, HIGH TEMP. CIRCUIT BREAKER PUSH-PULL, TRIP FREE ENVELOPE DRAWING		
	APPROVED N/A		SIZE	CODE IDENT NO.	2TC2
	SIGNATURES ON FILE. REFER TO ELECTRONIC CHANGE NOTICE.		C	82647	
			SCALE: 4X	SHEET 1 OF 1	